

# Heller

# F-16 DARK FALCON

30411



# DÉCOUVREZ LE MONDE DES PEINTURES ACRYLIQUES HELLER !

DISCOVER THE WORLD OF HELLER ACRYLIC PAINTS!  
ENTDECKEN SIE DIE WELT DER HELLER ACRYL-FARBEN!

**NEW**



- FACILE À UTILISER
- DILUABLE À L'EAU
- POTS DE PEINTURE STABLES
- BOUCHON À VIS SÉCURISÉ

- EASY TO USE
- DILUTABLE WITH WATER
- STABLE PAINT CANS
- SECURE SCREW CAP

- EINFACHE ANWENDUNG
- MIT WASSER VERDÜNNBAR
- STANDFESTE FARBDOSEN
- SICHERER SCHRAUBVERSCHLUSS

## Français

### Dark Falcon – Équipe de démonstration du F-16 belge

Le premier F-16 a été intégré à la flotte de la Force aérienne belge (BAF) en 1979 pour remplacer les F-104 Starfighter. À cette époque, la BAF avait décidé de créer une équipe de démonstration de F-16.

Cela leur a permis de présenter leurs jets et les compétences des pilotes militaires belges, et depuis, ils poursuivent cette tradition jusqu'à aujourd'hui.

En 2018, le Sr Cpt Darte, indicatif d'appel "Vador", est devenu le 19<sup>e</sup> pilote de F-16 à perpétuer cette tradition pendant trois années consécutives, en effectuant des manœuvres spectaculaires et techniques, comme des roulades planées très serrées et la roulade en 8 points, qui nécessitent précision et timing extrême.

La mission de l'équipe de démonstration consiste à présenter les capacités de la Force aérienne belge, notamment lors de shows aériens en Belgique et à l'étranger.

L'équipe avait conçu une peinture vraiment époustouflante et frappante pour le F-16A MLU "Fighting Falcon". Grâce à l'indicatif de Vador et à son lien étroit avec le "côté obscur", le thème principal de la peinture de l'appareil a été rapidement trouvé : le F-16 devait être le "Dark Falcon".

Le schéma sur le fuselage était resté le même pendant les trois années de service de Vador, mais la queue de l'avion avait changé chaque année. En 2019, la queue représentait une tête de faucon et comportait également l'inscription "F-16 40 years". Une attention particulière devait être accordée au drapeau belge sur l'empennage gauche. Lors des visites à l'étranger, le drapeau du pays concerné était apposé sur l'empennage droit afin de rendre hommage à l'accueil des organisateurs du salon et à l'amitié des passionnés du salon aérien dans toute l'Europe.

<b>Puissance</b>	128,9 kN
<b>Vitesse maximale</b>	Mach 2,02
<b>Envergure</b>	9,45 m

## English

### Dark Falcon – Belgian F-16 Demo Team

The first F-16 entered the Belgian Air Force (BAF) fleet in 1979 to replace the F-104 Starfighter. At that time the BAF decided to create an F-16 Demo Team.

This allowed them to show their jets and the skills of Belgian military pilots, and they have continued this tradition ever since.

In 2018, Sr Cpt Darte, call sign "Vador", became the 19th F-16 pilot to continue this tradition for three consecutive years, demonstrating spectacular and technical manoeuvres such as very tight glide rolls and the 8-point roll, which require precision and extreme timing.

The mission of the demonstration team is to show the capabilities of the Belgian Air Force, in particular at national and international air shows.

The team had designed a truly stunning and distinctive livery for the F-16A MLU "Fighting Falcon". With Vador's call sign and close association with the "Dark Side", the main theme for the aircraft's livery was quickly found, the F-16 was to become the "Dark Falcon".

The livery on the fuselage had remained the same throughout Vador's three years of service, but what had changed each year was the aircraft's tail. In 2019, the tail featured the head of a falcon and the words "F-16 40 years". Special attention was paid to the Belgian flag on the left tail. For visits abroad, the flag of the respective country was placed on the right tail to show the welcome of the airshow organisers and the friendship of airshow enthusiasts all over Europe.

<b>Power</b>	128,9 kN
<b>Max. Speed</b>	Mach 2,02
<b>Wingspan</b>	9.45 m

## Deutsch

### Dark Falcon – Belgisches F-16 Demo Team

Die erste F-16 wurde 1979 in die Flotte der belgischen Luftwaffe (BAF) aufgenommen, um die F-104 Starfighter zu ersetzen. Zu dieser Zeit hatte die BAF beschlossen, ein F-16-Demo-Team zu gründen.

Damit konnten Sie Ihre Jets und die Fähigkeiten der belgischen Militärpiloten präsentieren und setzen seitdem diese Tradition bis heute fort.

2018 wurde Sr. Cpt Darte, Rufzeichen "Vador" der 19. F-16-Pilot, der diese Tradition drei Jahre in Folge fortführte und zeigte dabei spektakuläre und technische Manöver, wie sehr enge Gleitrollen und die 8-Punkt-Rolle, die Präzision und extremes Timing erforderten.

Die Aufgabe des Demo-Teams besteht darin, die Fähigkeiten der belgischen Luftwaffe, vor allem bei Flugshows im In- und Ausland zu präsentieren.

Das Team hatte eine wirklich atemberaubende und auffallende Lackierung für die F-16A MLU "Fighting Falcon", entworfen. Durch Vadors Rufzeichen und die enge Verbindung zur "Dunklen Seite" war das Hauptthema für die Lackierung der Maschine schnell gefunden, die F-16 sollte der "Dark Falcon" werden.

Das Schema auf dem Rumpf war während Vadors dreijährigem Einsatz gleich geblieben, geändert hatte sich jedes Jahr das Heck des Flugzeugs. In 2019 zeigte das Heck den Kopf eines Falken und enthielt außerdem die Aufschrift "F-16 40 years". Ein besonderes Augenmerk war auf die belgische Flagge auf dem linken Leitwerk zu legen. Bei Besuchen im Ausland wurde die jeweilige Landesflagge auf dem rechten Leitwerk angebracht, um den Empfang durch die Airshow-Organisatoren und die Freundschaft der Airshow-Enthusiasten in ganz Europa zu würdigen.

<b>Leistung</b>	128,9 kN
<b>Höchstgeschwindigkeit</b>	Mach 2,02
<b>Flügelspannweite</b>	9,45 m

## Español

### Dark Falcon – Equipo de demostración del F-16 belga

El primer F-16 se incorporó a la flota de la Fuerza Aérea Belga (BAF) en 1979 para reemplazar a los F-104 Starfighter. En ese momento, la BAF decidió crear un equipo de demostración de F-16.

Esto le permitió presentar sus reactores y las habilidades de los pilotos militares belgas. Esta tradición continúa hasta el día de hoy.

En 2018, el Cap. Darte, indicativo «Vader», se convirtió en el 19.º piloto de F-16 en perpetuar esta tradición durante tres años consecutivos, realizando maniobras espectaculares y técnicas, como «loops» planos muy cerrados y el «barrel roll» de 8 caras, que requieren una precisión y una sincronización extremas.

La misión del equipo de demostración es presentar las habilidades de la Fuerza Aérea Belga, especialmente en espectáculos aéreos en Bélgica y en el extranjero.

El equipo ha diseñado una decoración realmente original e impactante para el F-16A MLU «Fighting Falcon». Gracias al indicativo «Vador» y a su

<b>Potencia</b>	128,9 kN
<b>Máxima velocidad</b>	Mach 2,02
<b>Envergadura</b>	9,45 m

estrecha relación con el «lado oscuro», el tema principal de la librea de la aeronave se encontró rápidamente: el F-16 iba a llamarse «Dark Falcon». El patrón en el fuselaje se mantuvo igual durante los tres años de servicio de Vador, pero la cola del avión cambió cada año. En 2019, la cola representaba una cabeza de halcón y también llevaba la inscripción «F-16 40 years». Se prestó especial atención a la bandera belga en el lado izquierdo de la cola. Durante las visitas al extranjero, se colocaba la bandera del país anfitrión en la cola derecha para rendir homenaje a la hospitalidad de los organizadores del espectáculo y a la amistad de los aficionados de toda Europa.

## Italiano

### Dark Falcon - Squadra acrobatica dell'F-16 belga

Il primo F-16 è entrato a far parte della flotta aerea belga (BAF) nel 1979 per sostituire gli F-104 Starfighter.

A quel tempo, la BAF aveva deciso di creare una squadra acrobatica di F-16. Ciò le ha permesso di presentare i suoi jet e le competenze dei piloti militari belgi. Questa tradizione continua ancora oggi.

Nel 2018, Sir Cpt Darte, nome in codice "Vador", è diventato il 19° pilota di F-16 a perpetuare questa tradizione per tre anni consecutivi, effettuando manovre spettacolari e tecniche, come loop molto stretti e il tonneau a 8 facce, che richiedono estrema precisione e tempismo.

La missione della squadra acrobatica è presentare le capacità dell'Aeronautica belga, in particolare durante gli spettacoli aerei in Belgio e all'estero. Il team ha progettato una livrea davvero originale e insolita per l'F-16A MLU "Fighting Falcon". Dato il nome in codice Vader e il suo stretto legame con il "lato oscuro", è stato facile trovare il tema principale della livrea del velivolo: l'F-16 doveva essere il "Dark Falcon".

Lo schema sulla fusoliera è rimasto invariato nei tre anni di servizio di Vader, mentre la coda è stata cambiata ogni anno.

Nel 2019, la coda rappresentava una testa di falco con la scritta "F-16 40 anni". Particolare attenzione è stata dedicata alla bandiera belga sullo stabilizzatore verticale sinistro. Durante le visite all'estero, sullo stabilizzatore verticale destro veniva apposta la bandiera del paese ospitante per ringraziare dell'accoglienza gli organizzatori dell'evento e l'amicizia dimostrata dagli appassionati in tutta Europa.

<b>Potenza</b>	128,9 kN
<b>Massima velocità</b>	Mach 2,02
<b>Apertura alare</b>	9,45 m

## Nederlands

### Dark Falcon - Belgisch F-16 Demonstratieteam

De eerste F-16 sloot zich in 1979 aan bij de Belgische luchtmacht (BAF) om de F-104 Starfighter te vervangen. Op dat moment besloot de BAF een F-16 demonstratieteam op te richten.

Dit gaf het bedrijf de kans om zijn jets en de vaardigheden van Belgische militaire piloten in de kijker te zetten. Deze traditie zet zich vandaag voort.

In 2018 werd Sr Cpt Darte, ook wel 'Vador' genoemd, de 19e F-16 piloot die deze traditie drie jaar op rij voortzette door spectaculaire en technische manoeuvres uit te voeren, zoals zeer krappe glijvluchten en de 8-kantige looprol, die uiterste precisie en timing vereisen.

De missie van het demonstratieteam is om de capaciteiten van de Belgische luchtmacht onder de aandacht te brengen, met name op luchtshows in België en in het buitenland.

Het team heeft een werkelijk originele en verbluffende kleurencombinatie ontworpen voor de F-16A MLU 'Fighting Falcon'. Dankzij de Vader-aanduiding en de nauwe band met de 'duistere kant' was het hoofdthema van de vliegtuigkleuren snel gevonden: de F-16 moest de 'Darth Falcon' worden.

Het patroon op de romp bleef hetzelfde tijdens de drie jaar dat Vador in dienst was, maar de staart van het vliegtuig veranderde elk jaar.





















In 2019 vertegenwoordigde de staart de kop van een havik en had ook de inscriptie "F-16 40 jaar". Bijzondere aandacht werd besteed aan de Belgische vlag op het linker staartvlak. Tijdens bezoeken aan het buitenland werd de vlag van het gastland op de rechter staart bevestigd als eerbetoon aan de gastvrijheid van de organisatoren van de show en de vriendschap van liefhebbers in heel Europa.

<b>Vermogen</b>	128,9 kN
<b>Maximale snelheid</b>	Mach 2,02
<b>Spanwijdte</b>	9,45 m

1/48

F-16 DARK FALCON

30411

 11 Argent métallique Silver Metallic Silber metallisch	 14 Bleu de france brillant French Blue Gloss Französischblau glänzend	 16 Or métallique Gold Metallic Gold metallisch	 22 Blanc brillant White Gloss Weiß glänzend	 25 Bleu mat Blue Matt Blau matt	 27 Gris mer mat Sea Grey Matt Seegrau matt	 33 Noir mat Black Matt Schwarz matt
 53 Gris métallique Gunmetal Metallic Grau metallisch	 64 Gris clair mat Light Grey Matt Hellgrau matt	 69 Jaune brillant Yellow Gloss Gelb glänzend	 81 Jaune pale mat Pale Yellow Matt Blassgelb matt	 85 Noir de charbon satiné Coal Black Satin Kohlenschwarz seidenmatt	 86 Olive clair mat Light Olive Matt Olivgrün hell matt	 87 Gris acier mat Steel Grey Matt Stahlgrau matt
 92 Gris fer mat Iron Grey Matt Eisengrau matt	 106 Gris ocean mat Ocean Grey Matt Ozeangrau matt	 113 Rouille mat Rust Matt Rost matt	 127 Gris fantome US satine US Ghost Grey Satin US-Schattengrau seidenmatt	 130 Blanc satine White Satin Weiß seidenmatt	 321 Rouge transparent Red Transparent Rot transparent	 325 Vert transparent Green Transparent Grün transparent

2

Numéro de phase  
Step number  
Schrittnummer  
Número de fase

56

Référence de couleur  
Colour reference no  
Farbangabe  
Referencia de color

37

Numéro de pièce  
Part number  
Teilenummer  
Número de pieza

6

Numéro de decal  
Decal number  
Abziehbildnummer  
Número de calcomanía

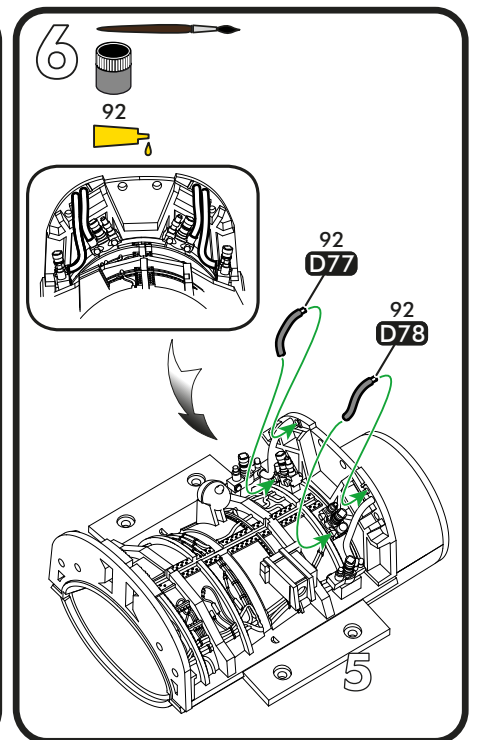
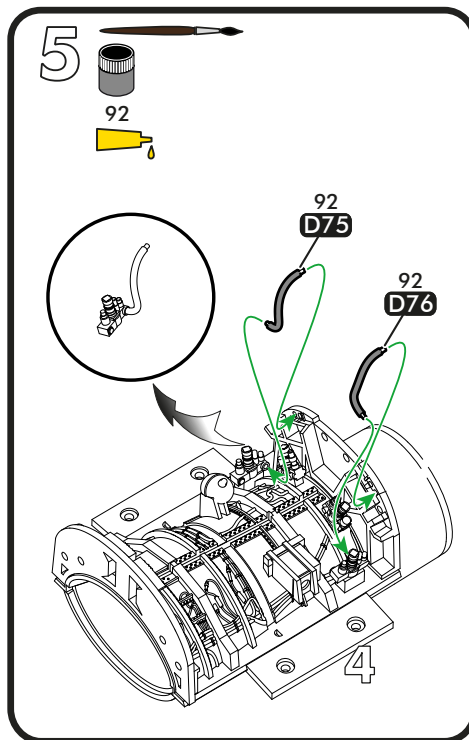
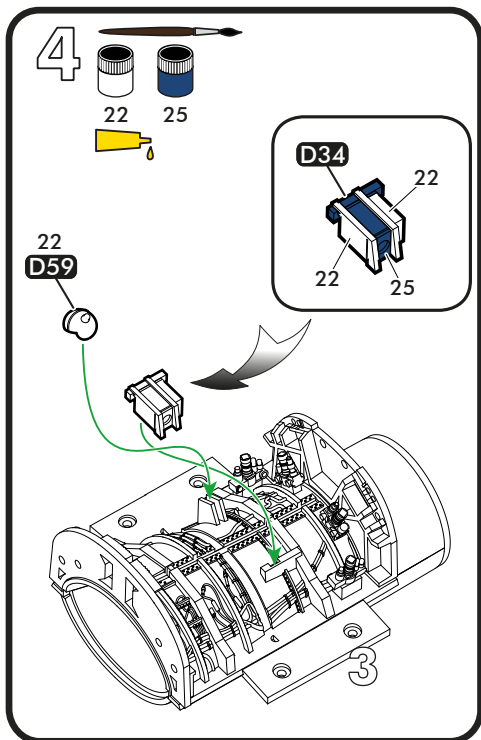
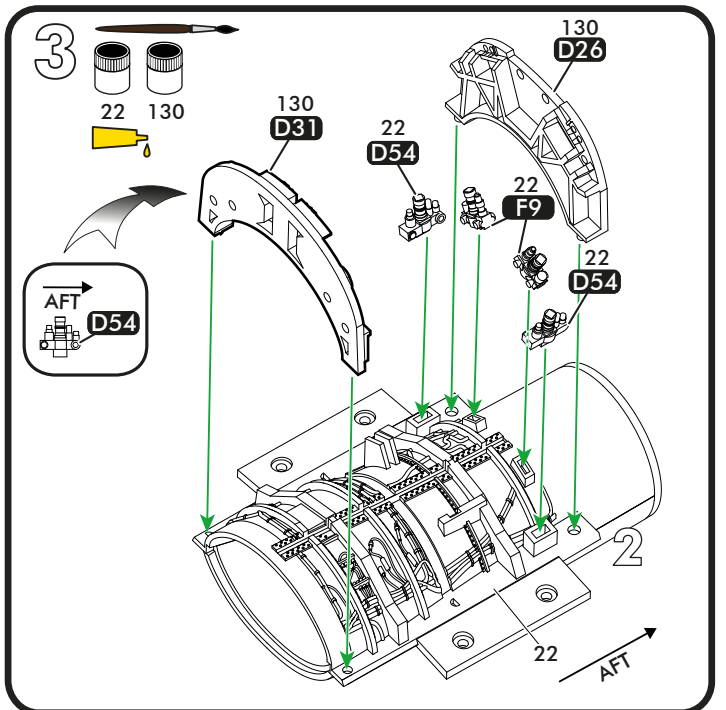
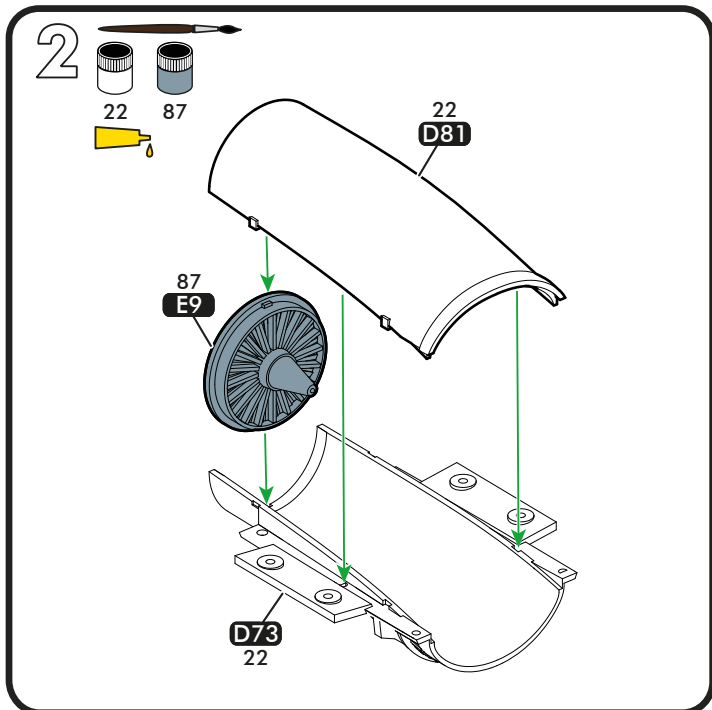
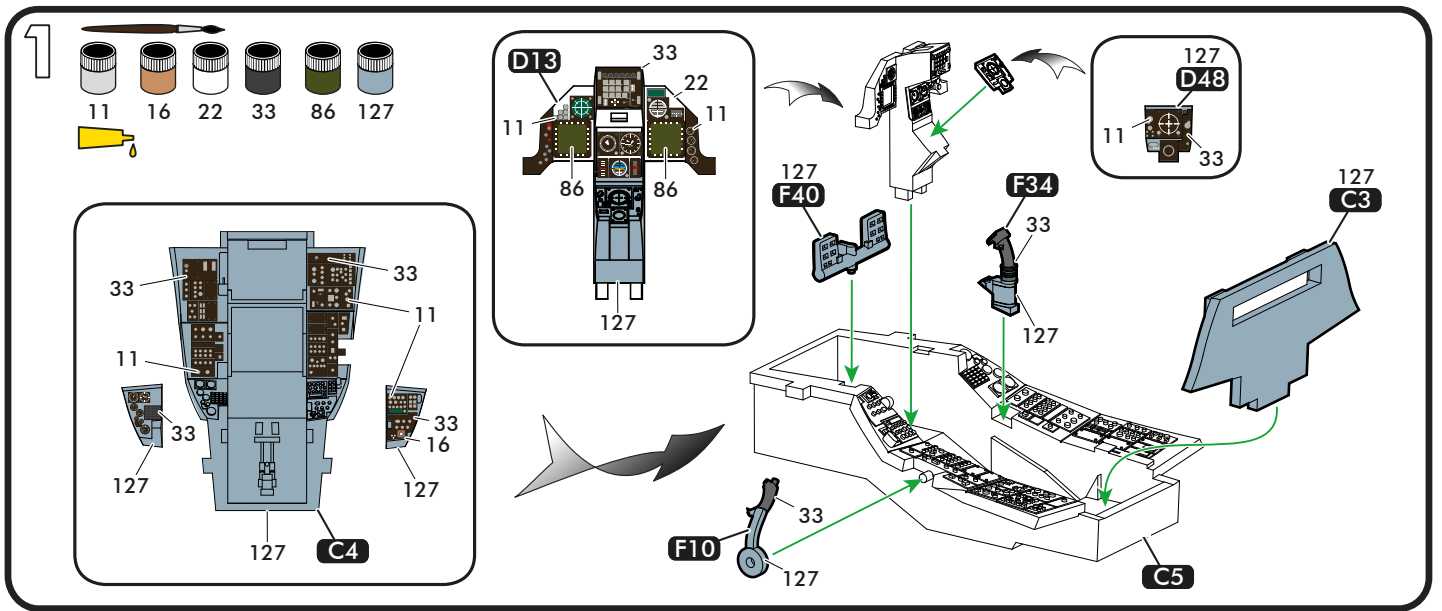

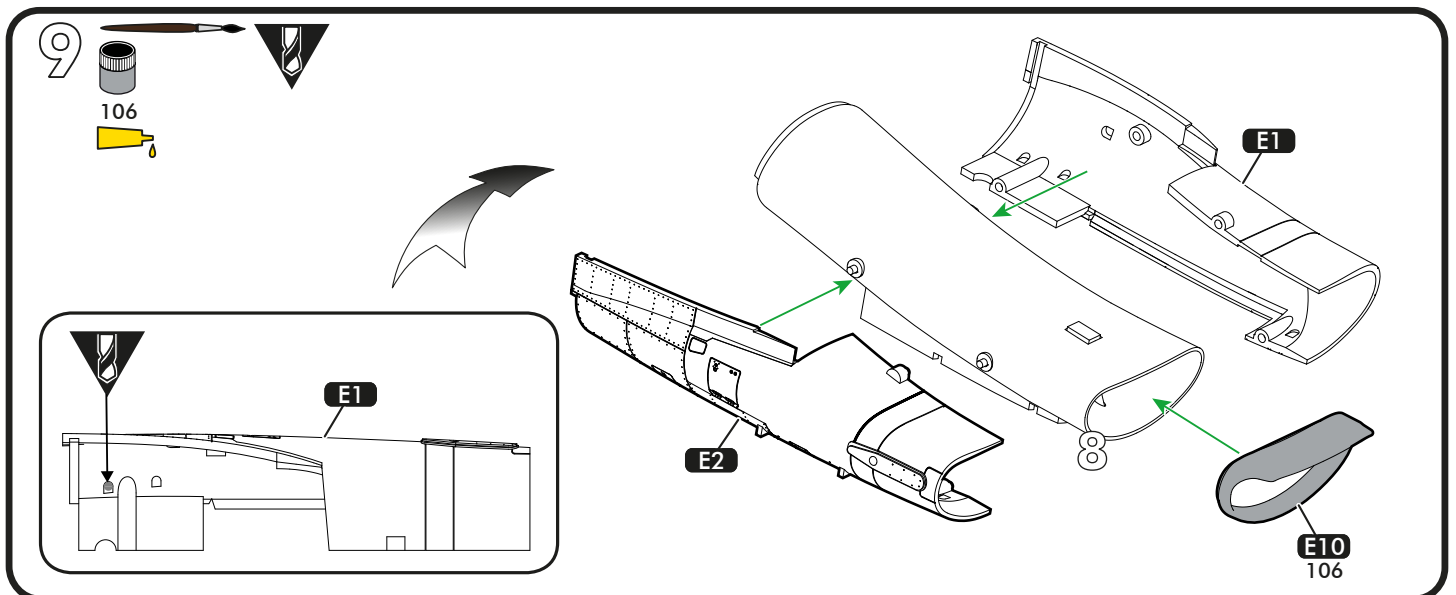
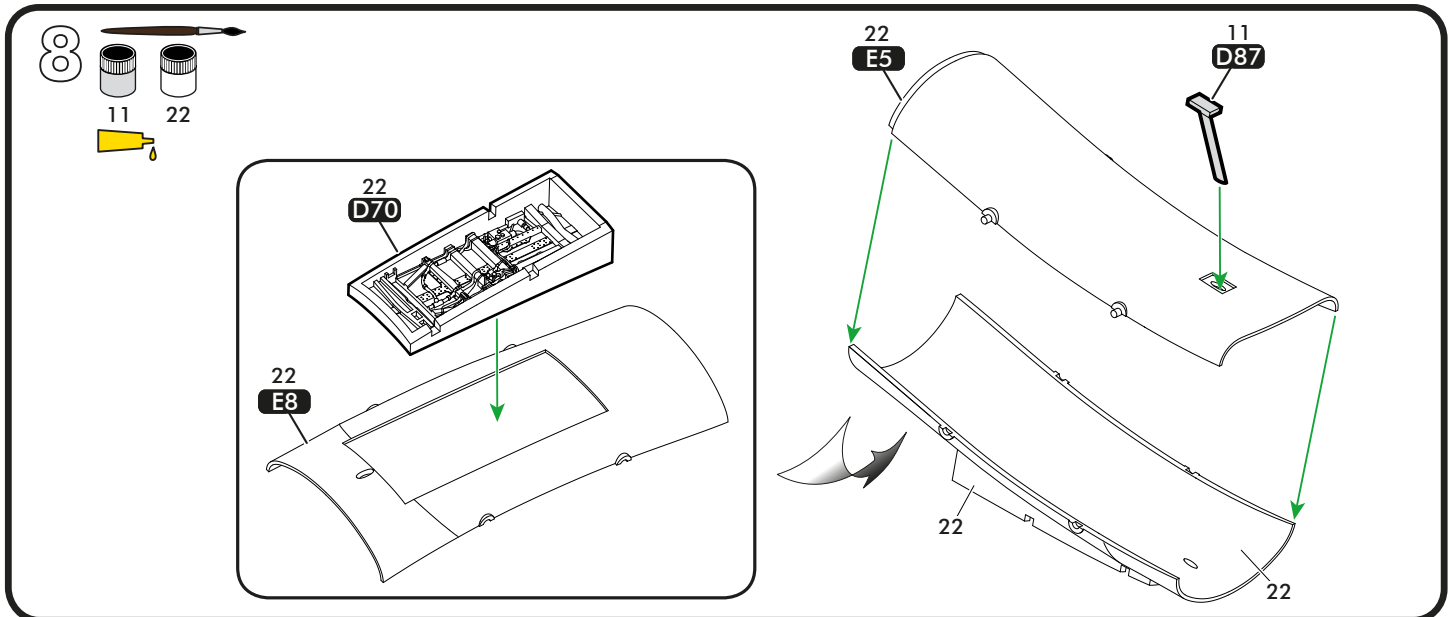
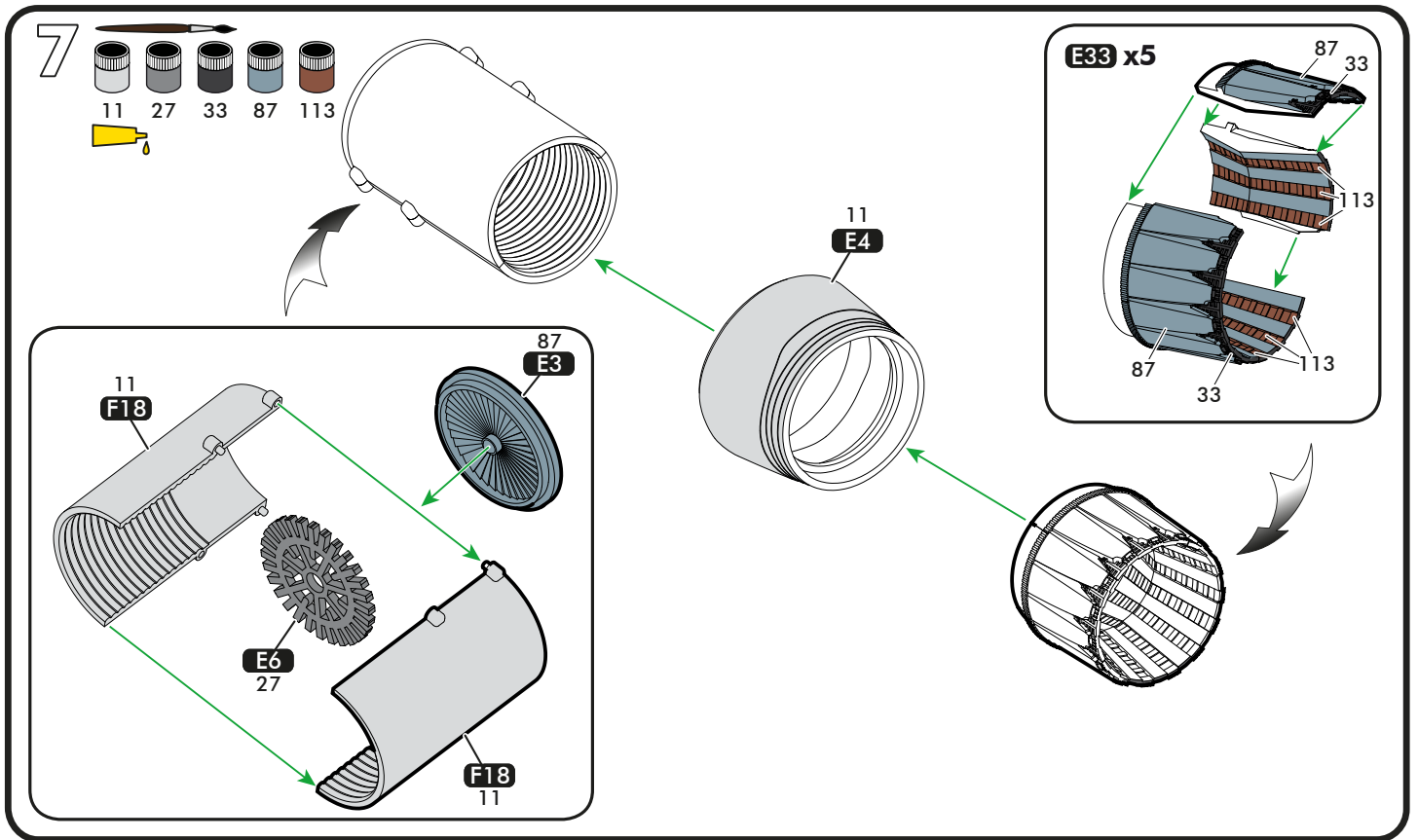

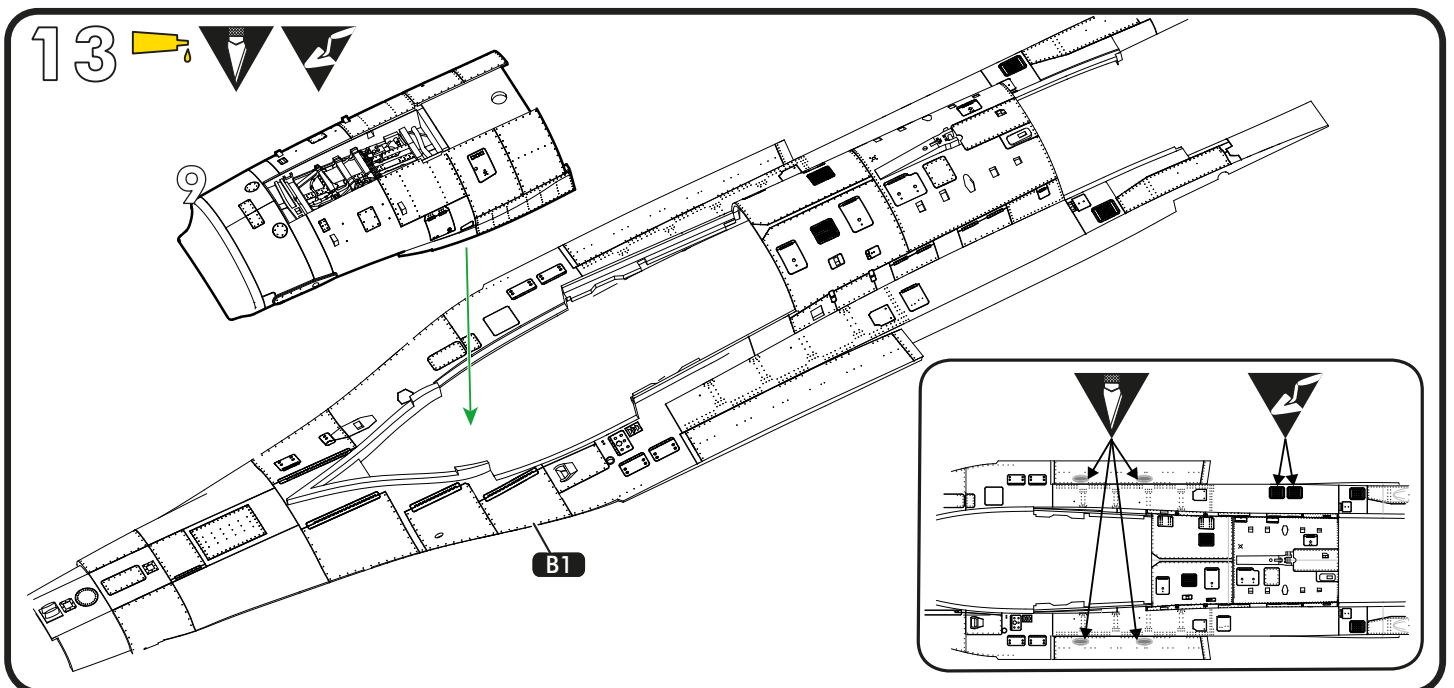
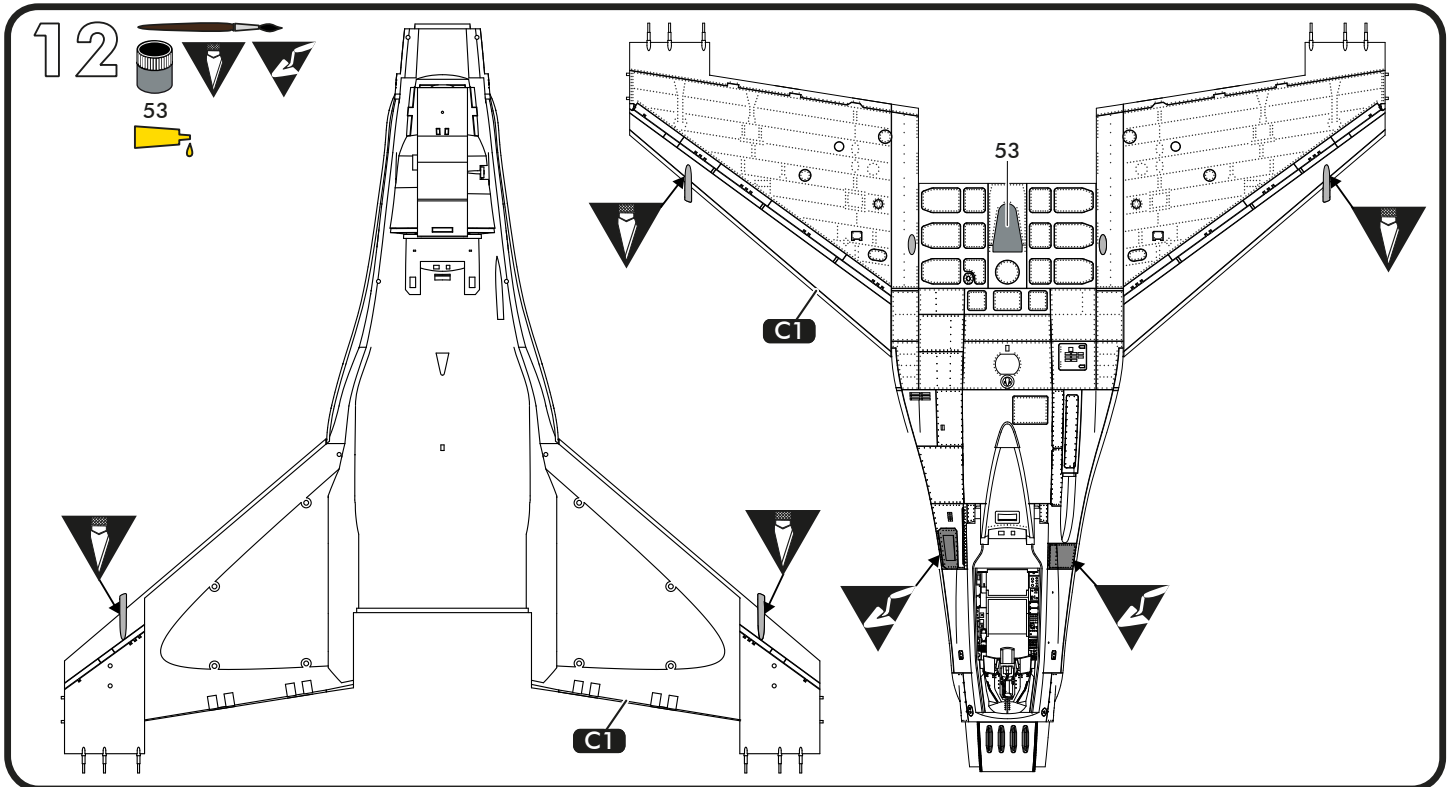
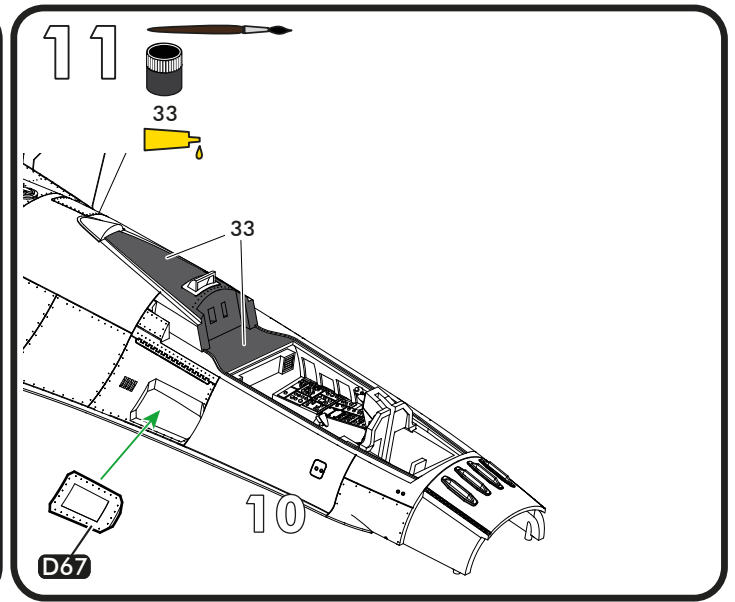
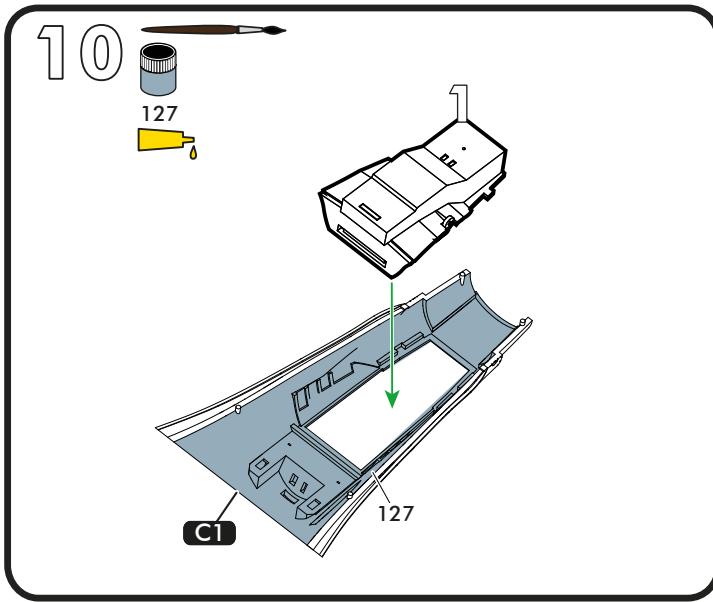

14 

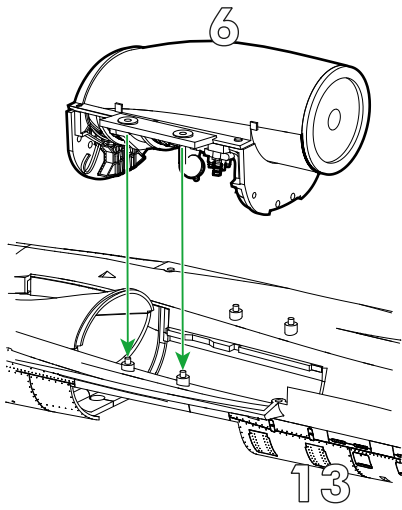

15 

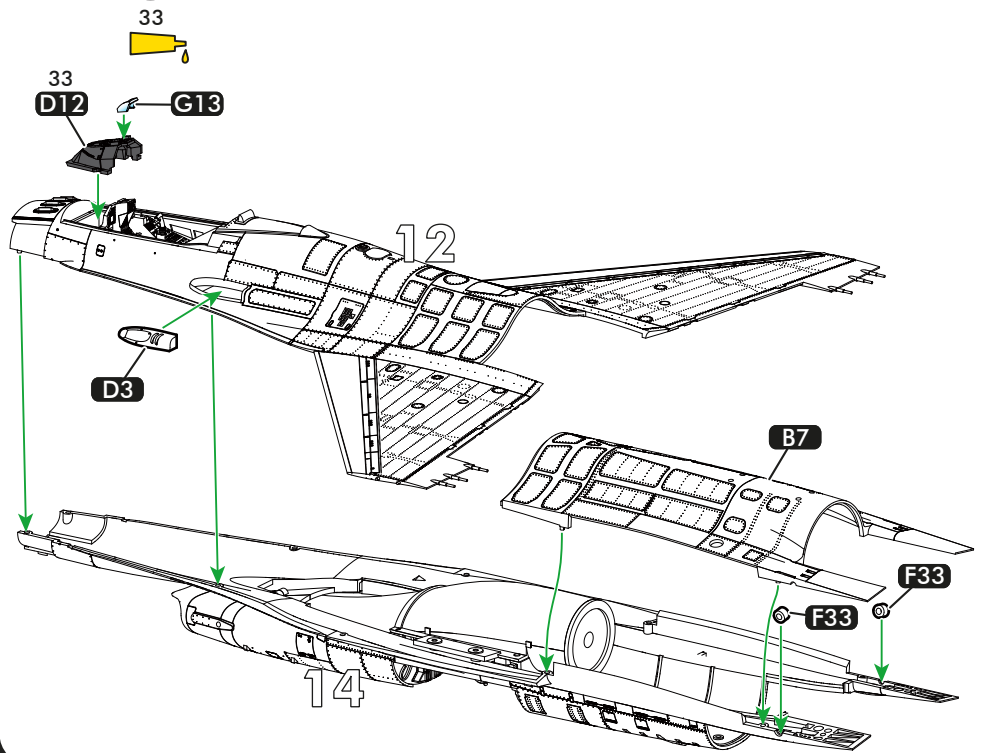

16 

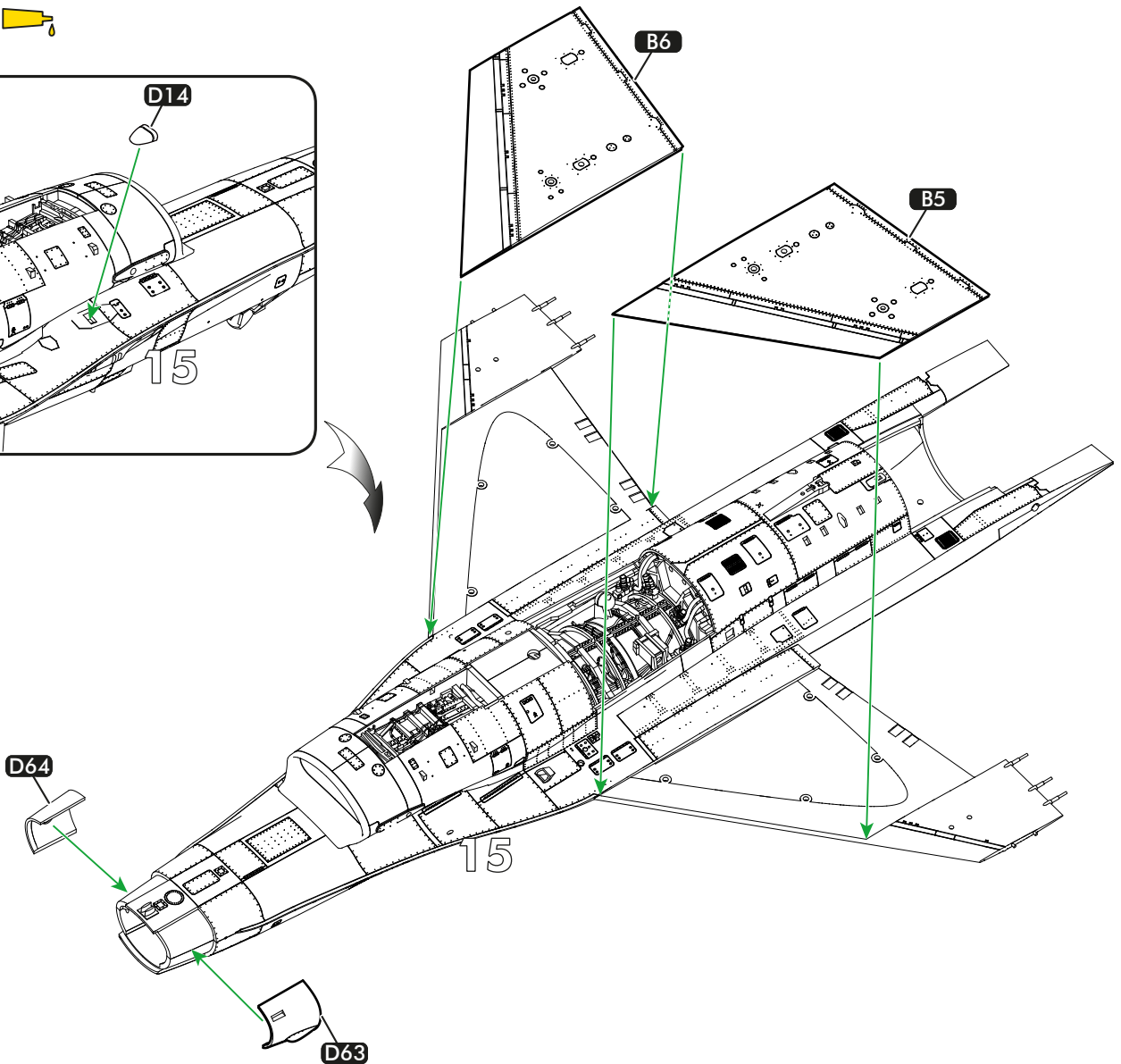
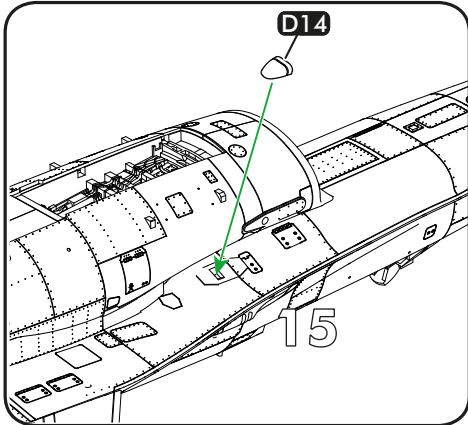



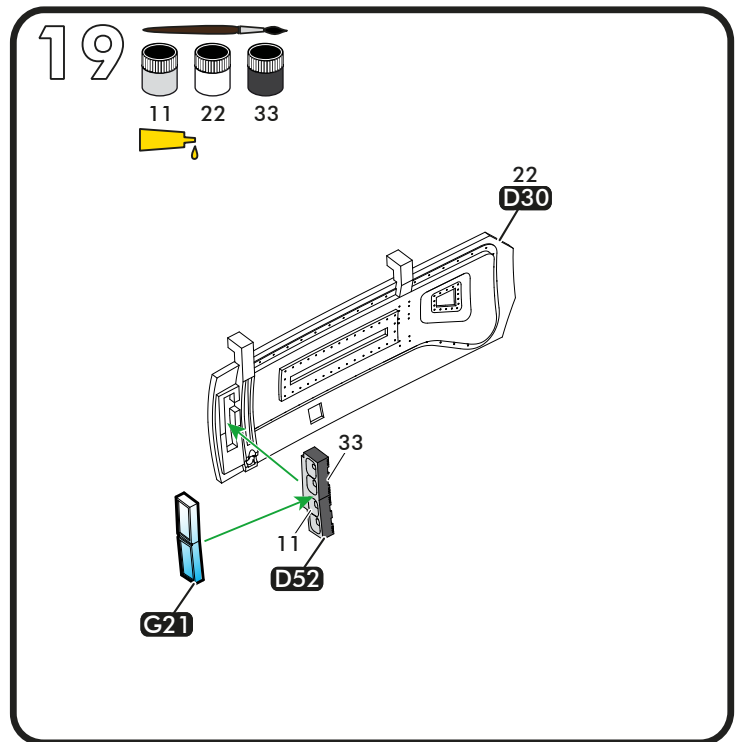
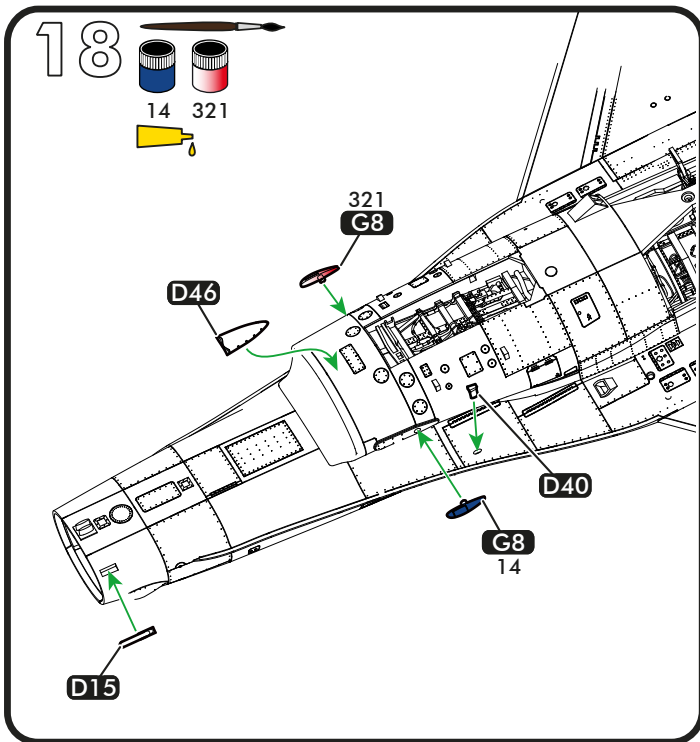
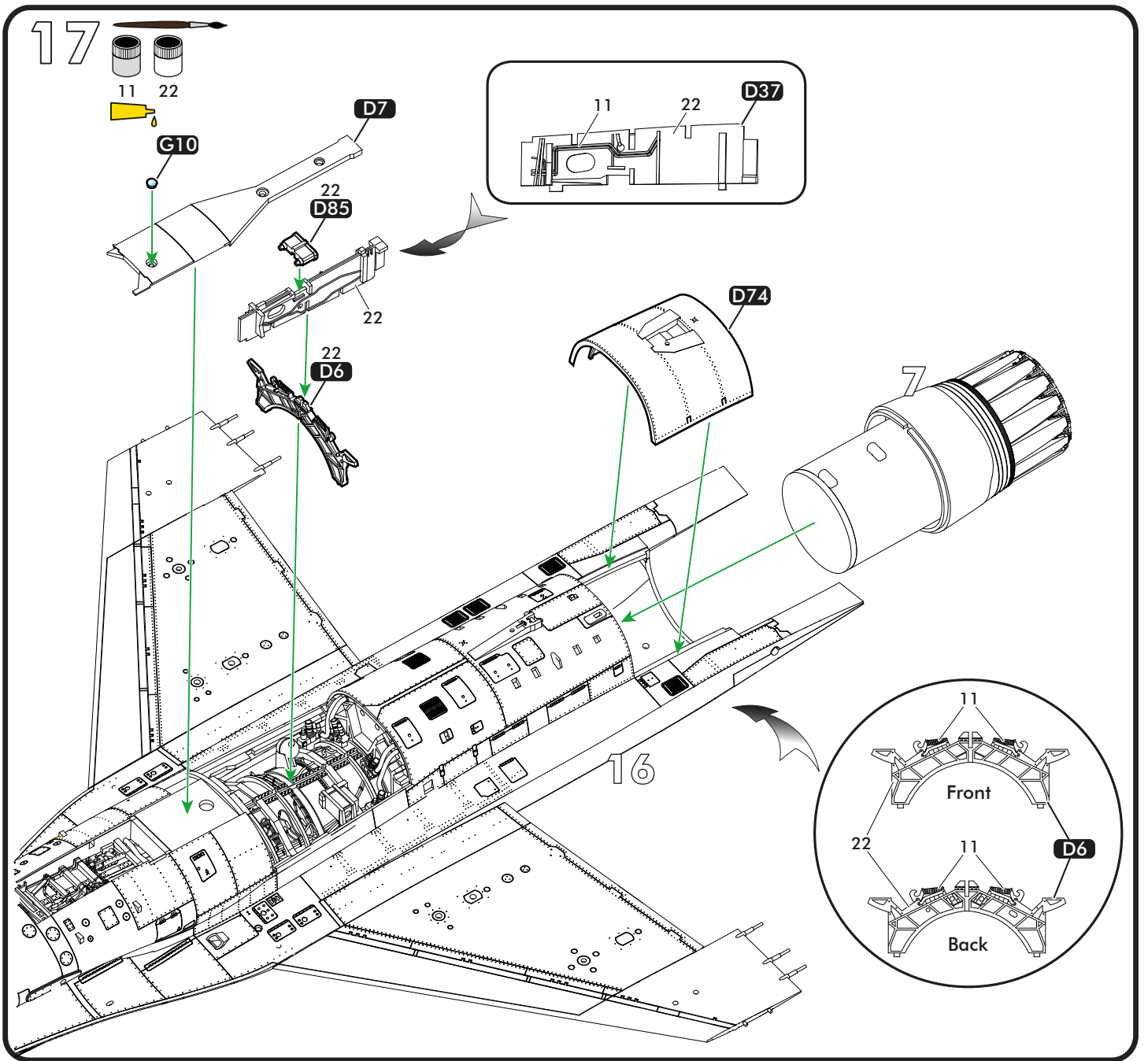

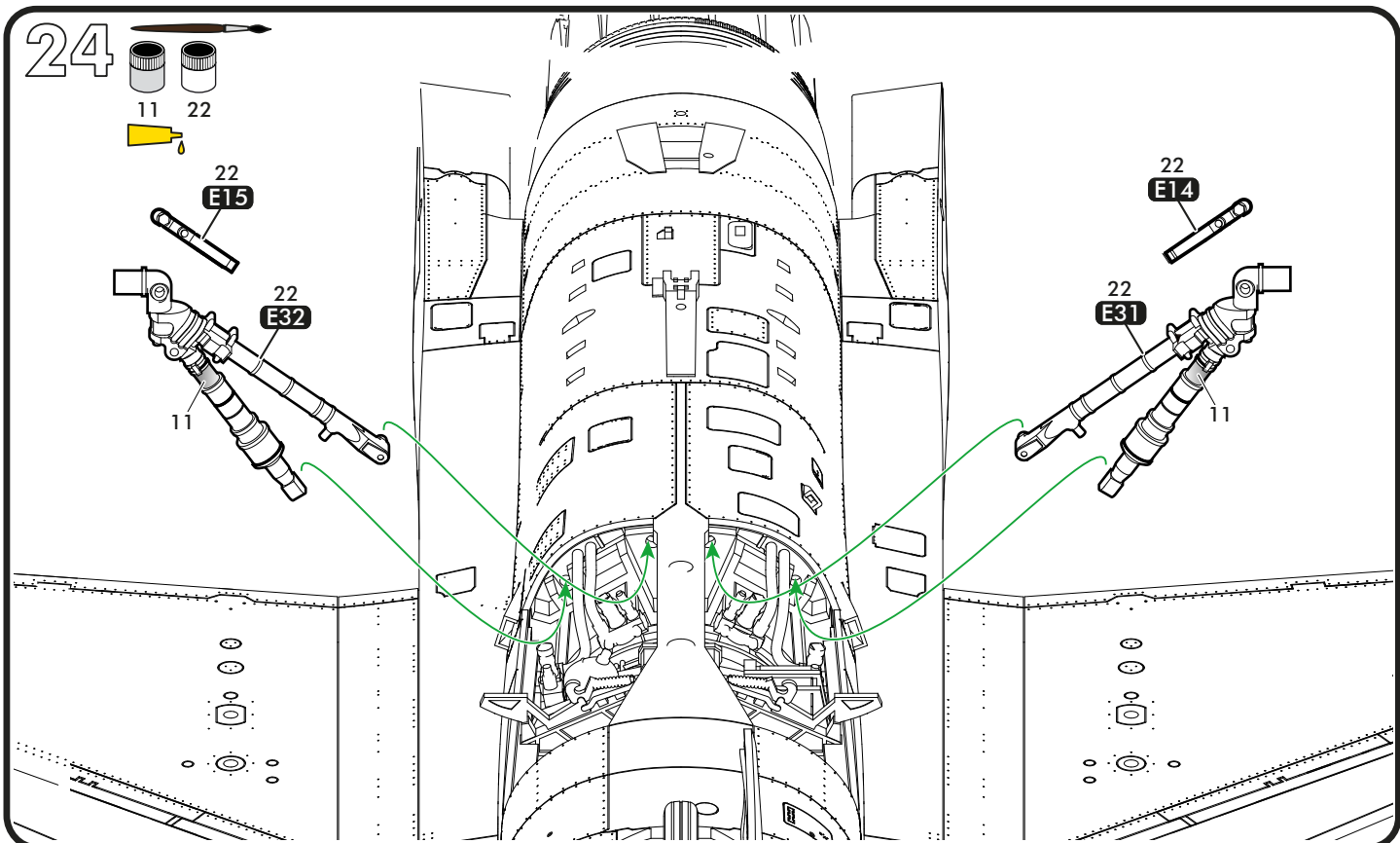
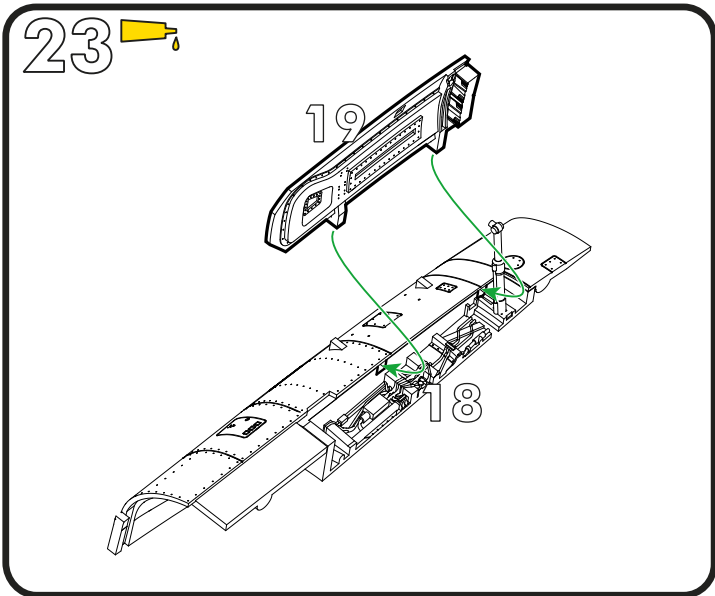
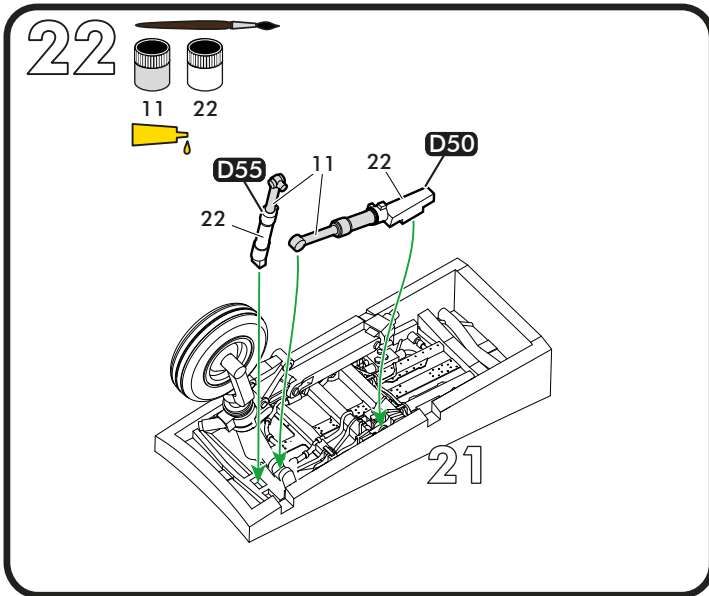
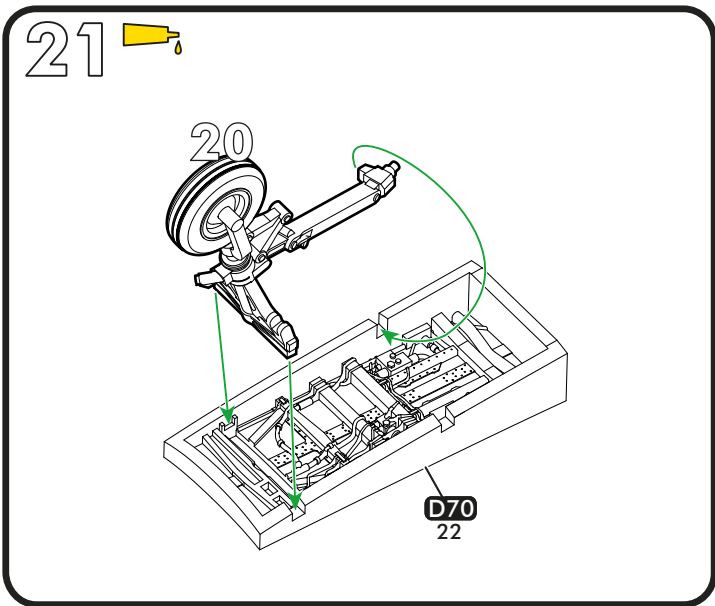
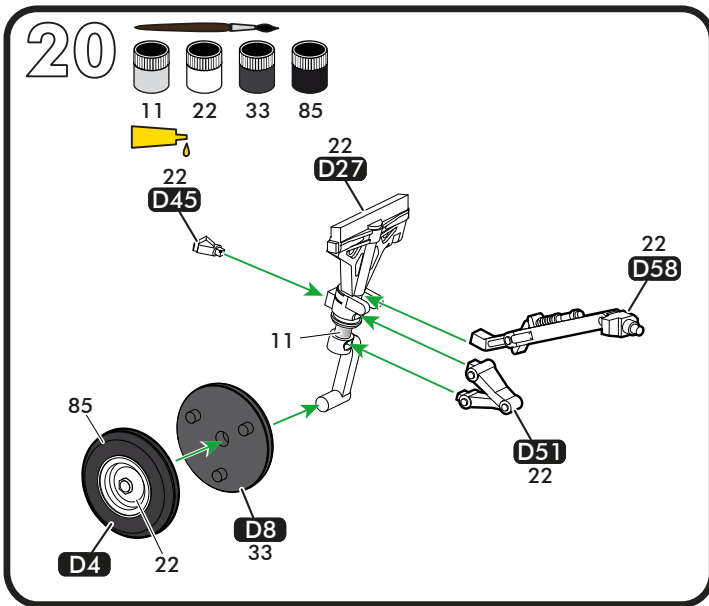

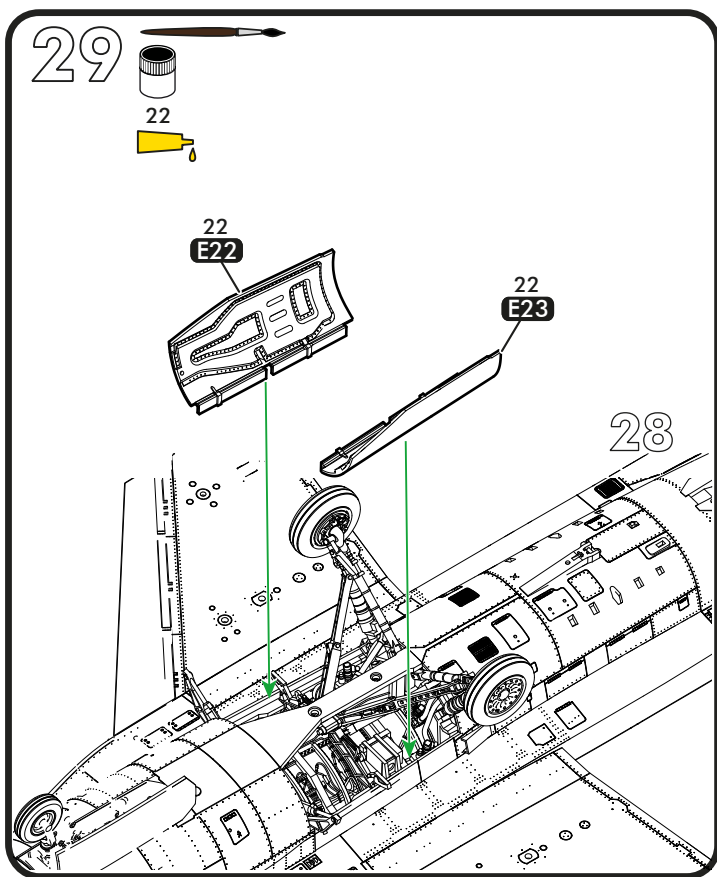
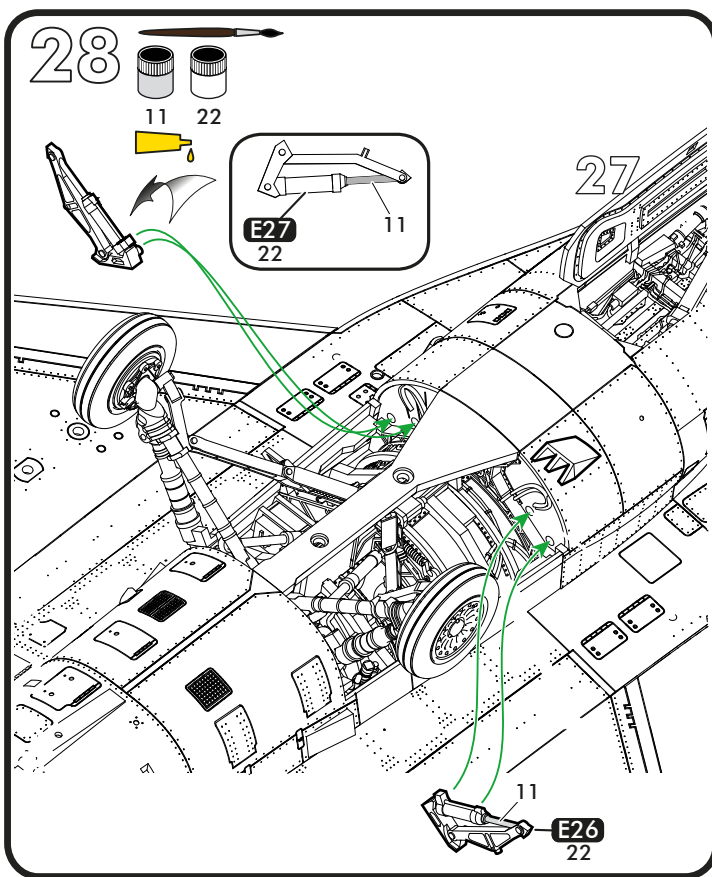
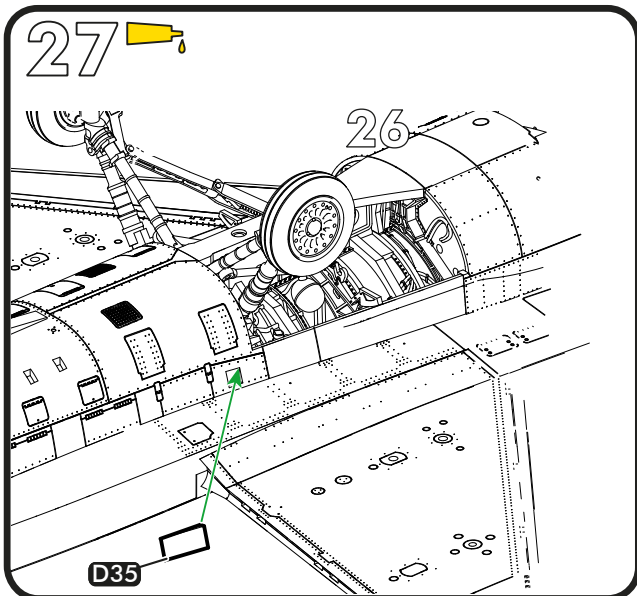
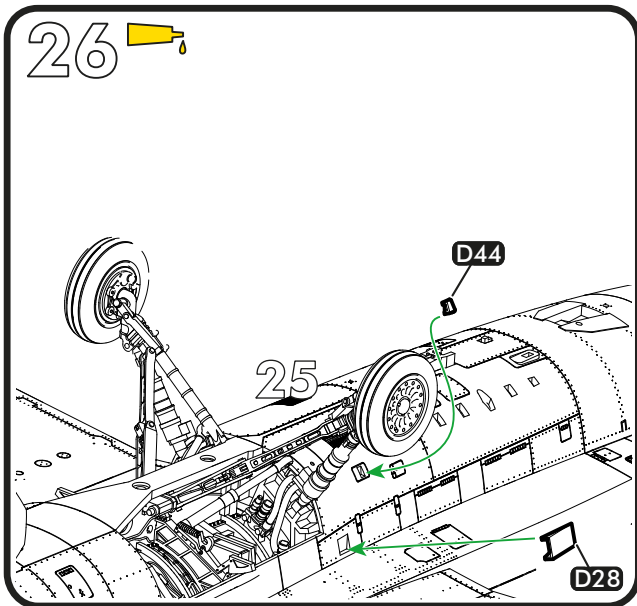
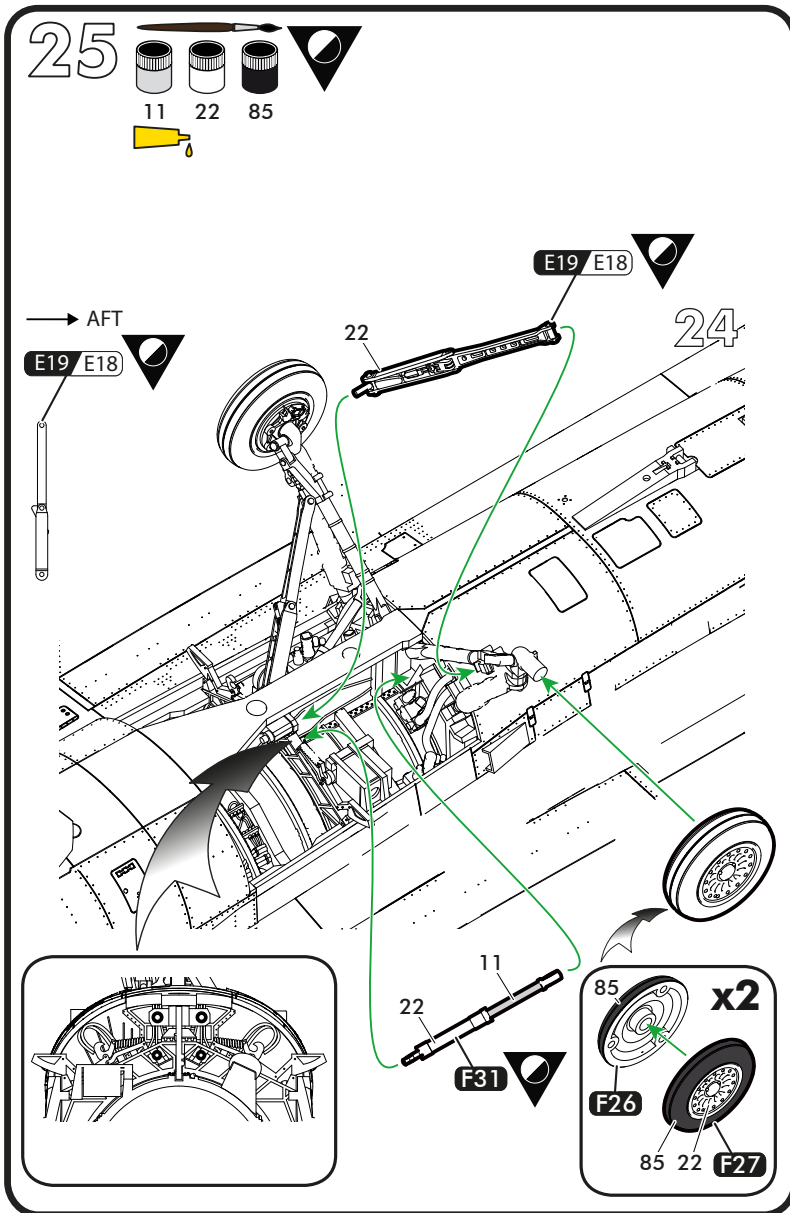

30

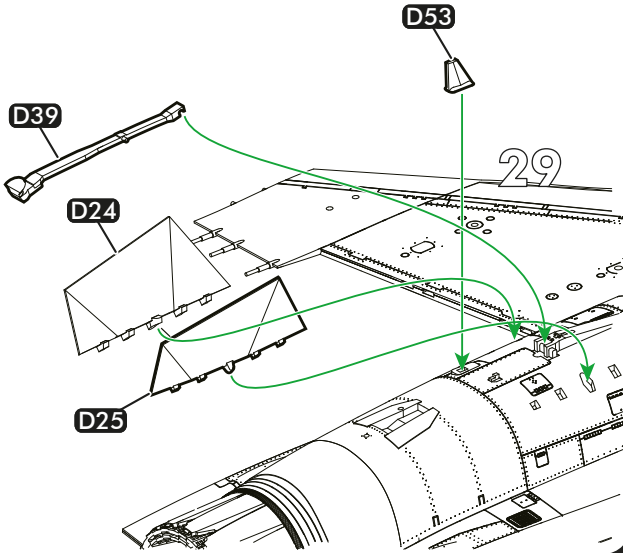

31

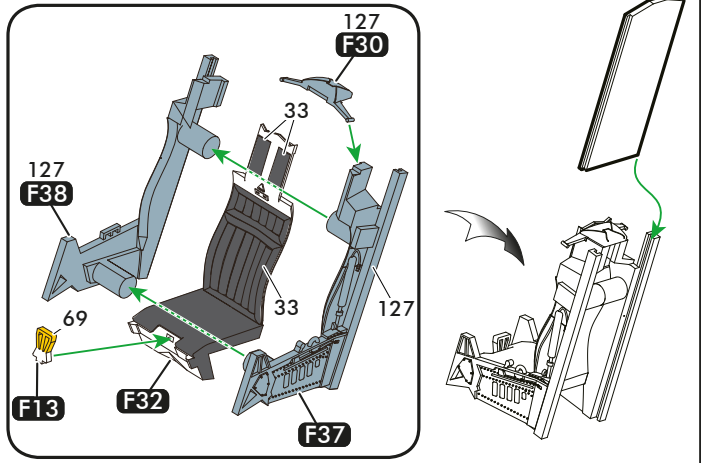
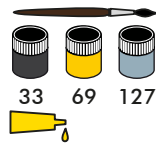

32

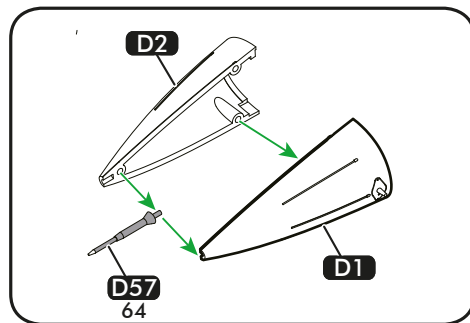
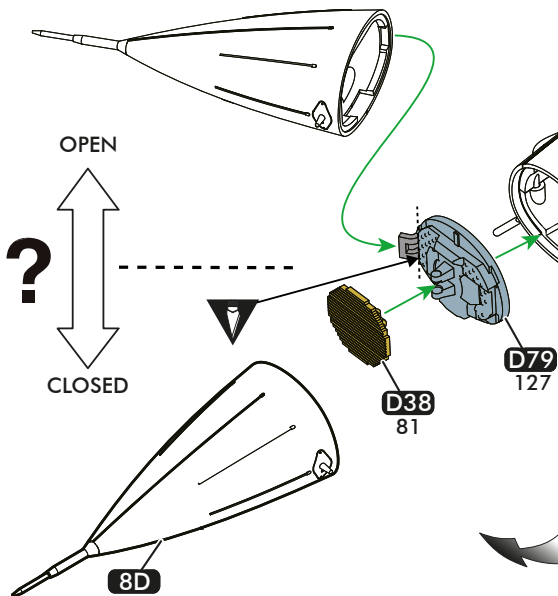
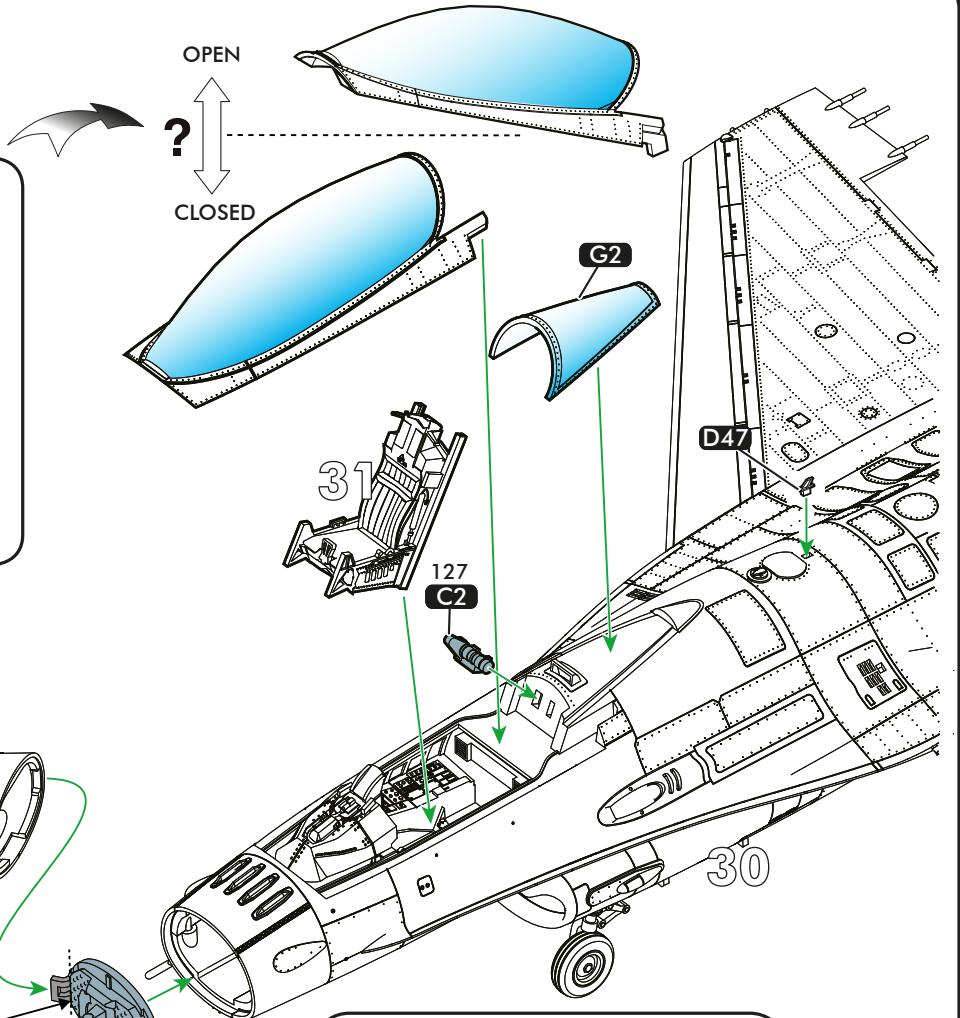
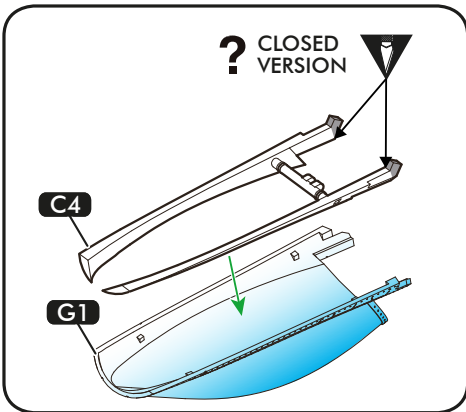

33 

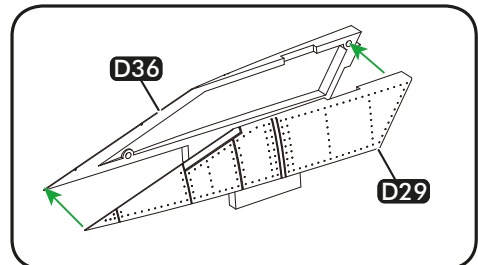
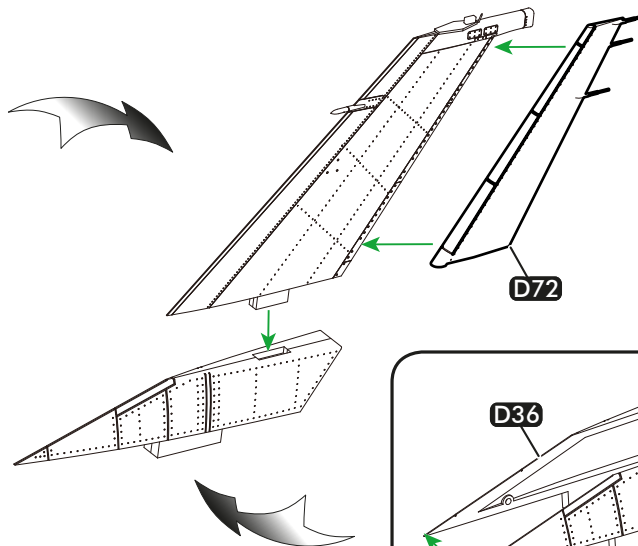
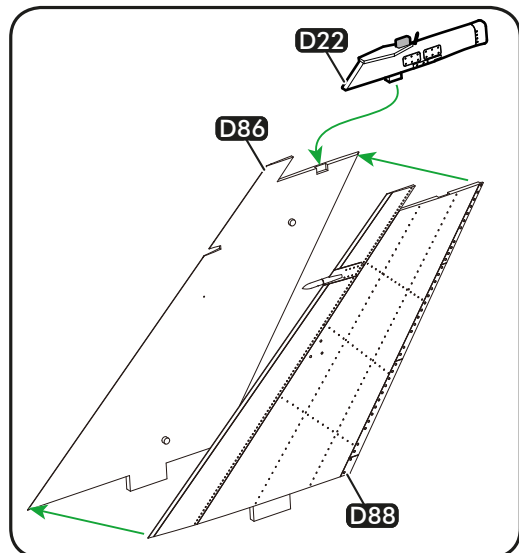

34 

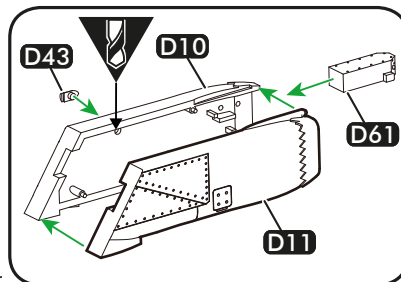
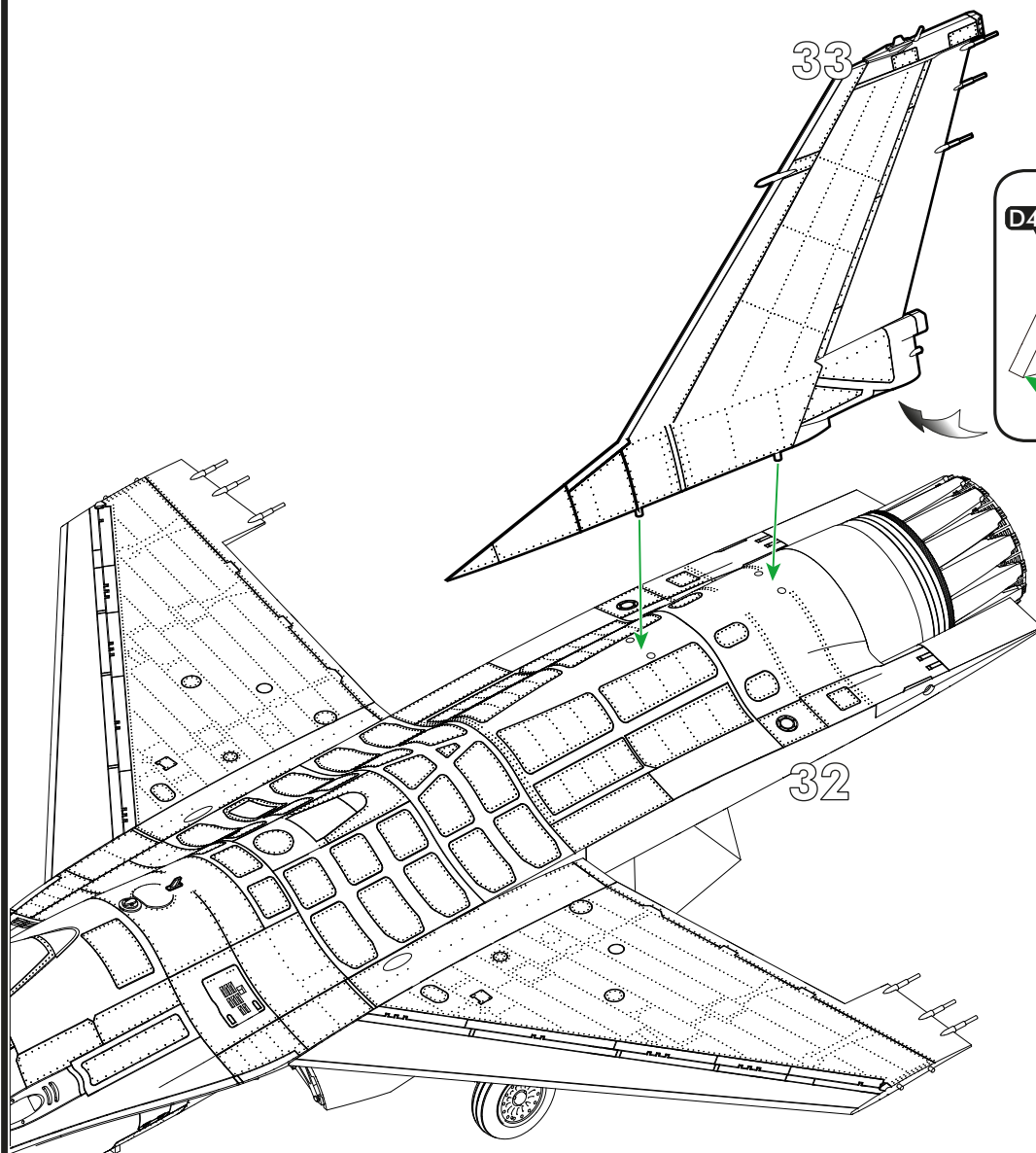

35

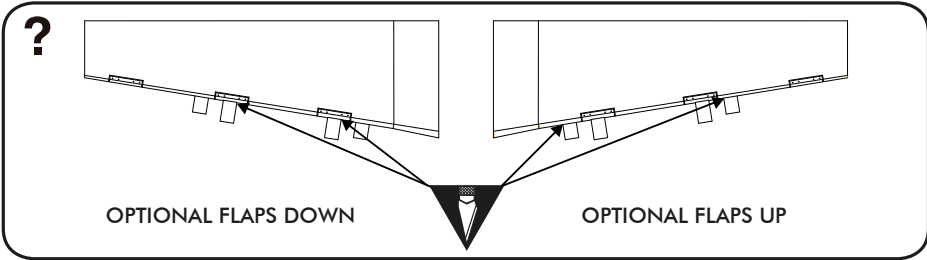
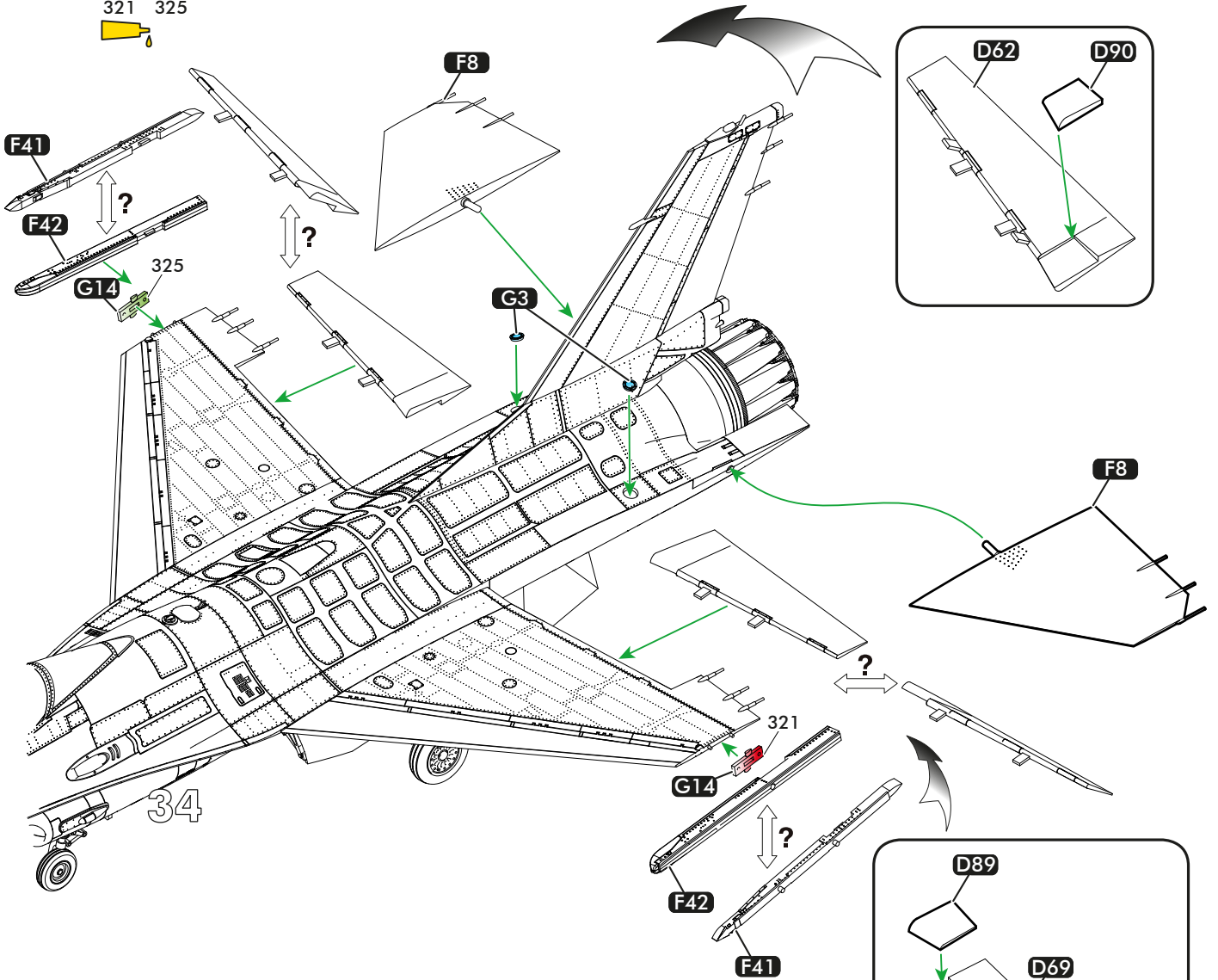
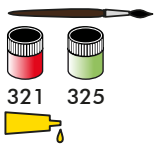

36

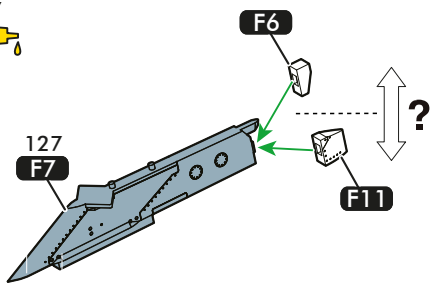
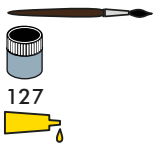

WING TANK PYLON

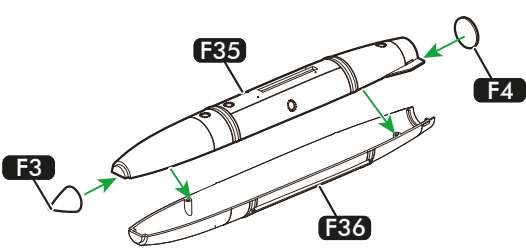

370 GALLON WING TANK

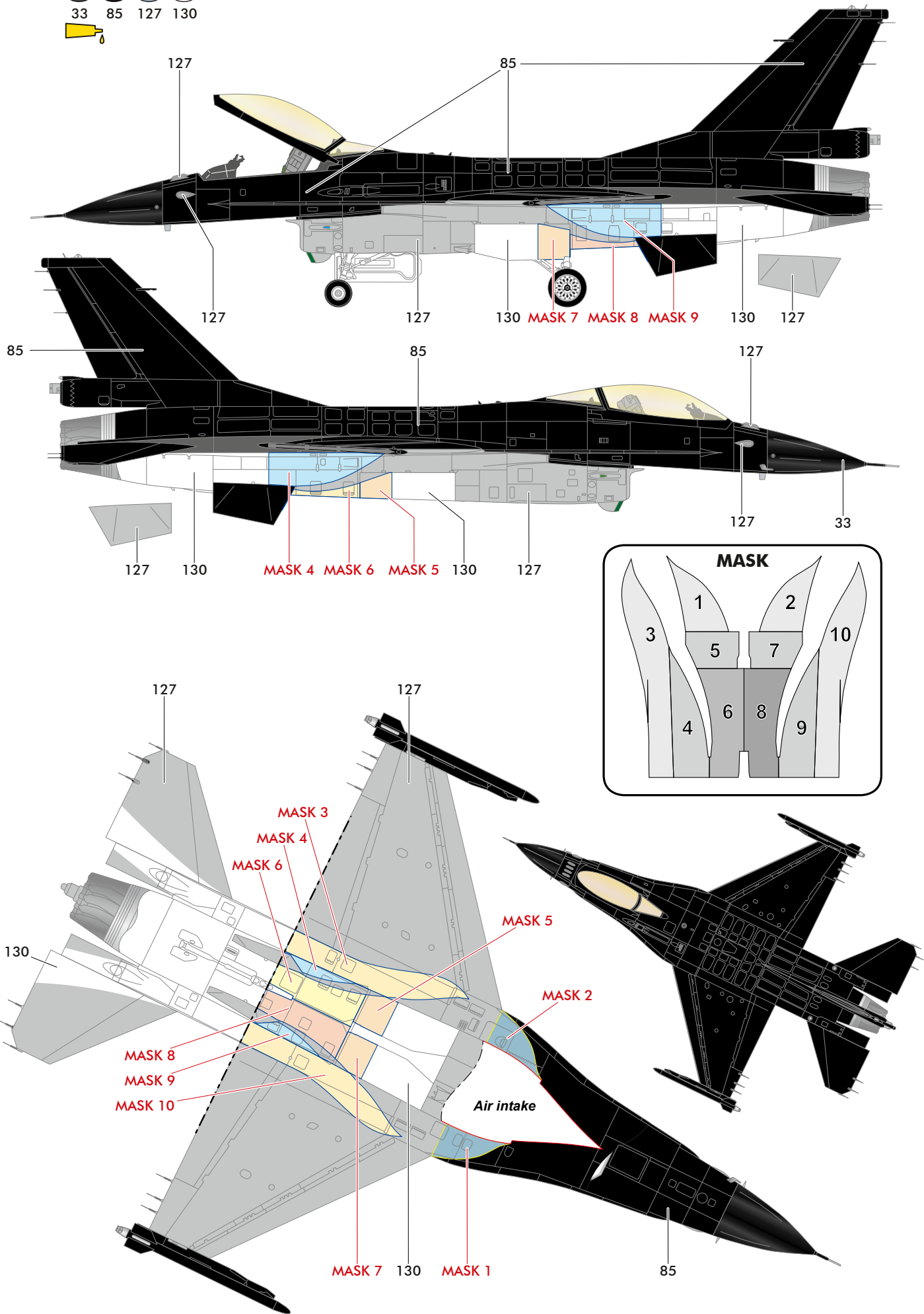
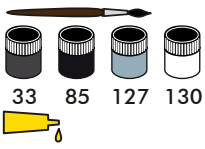

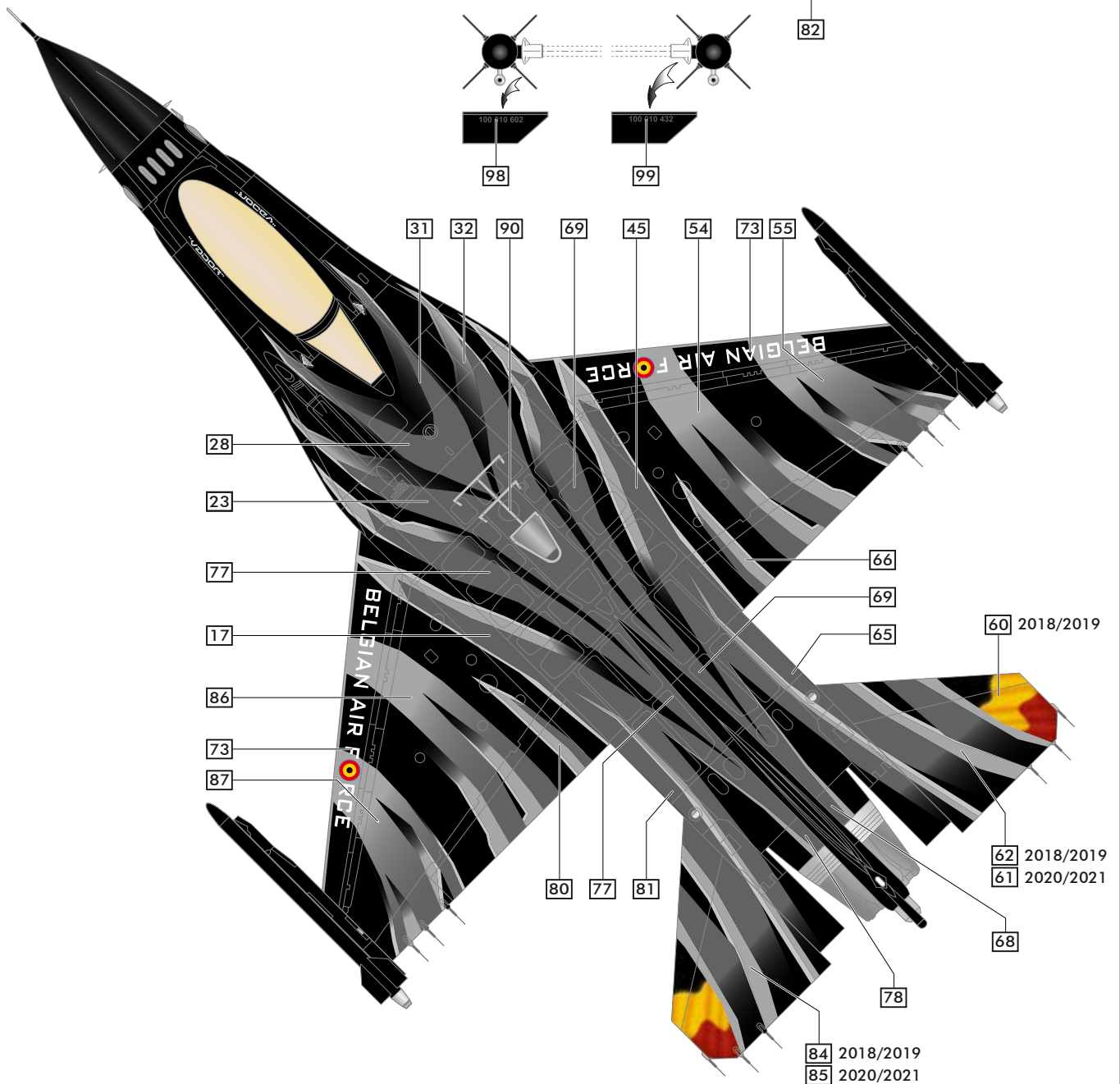
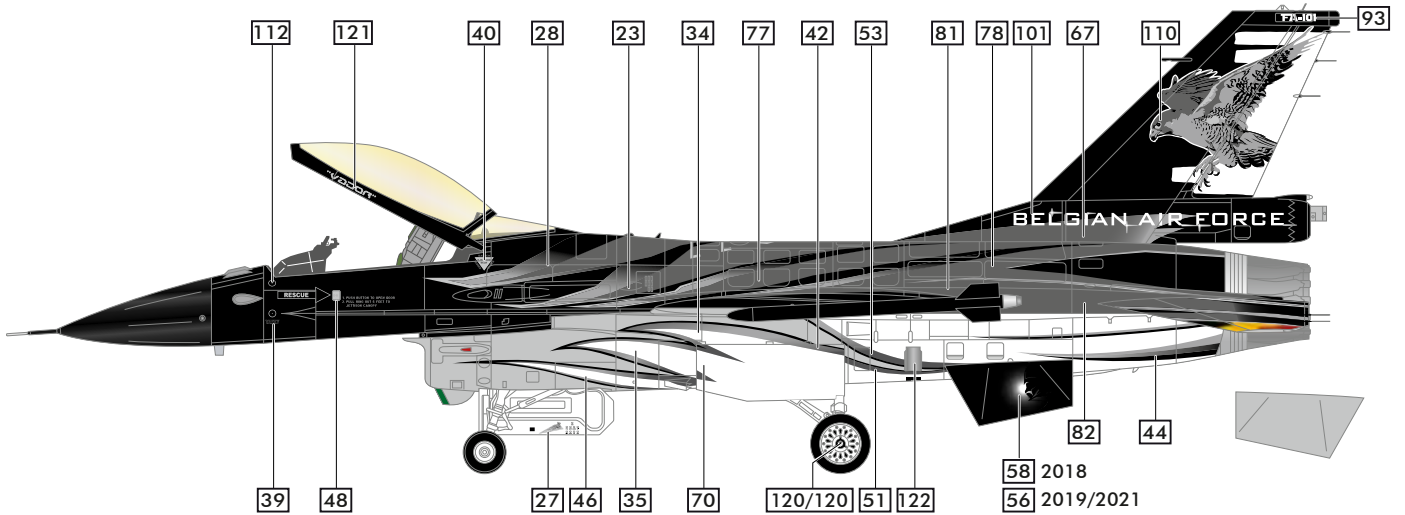



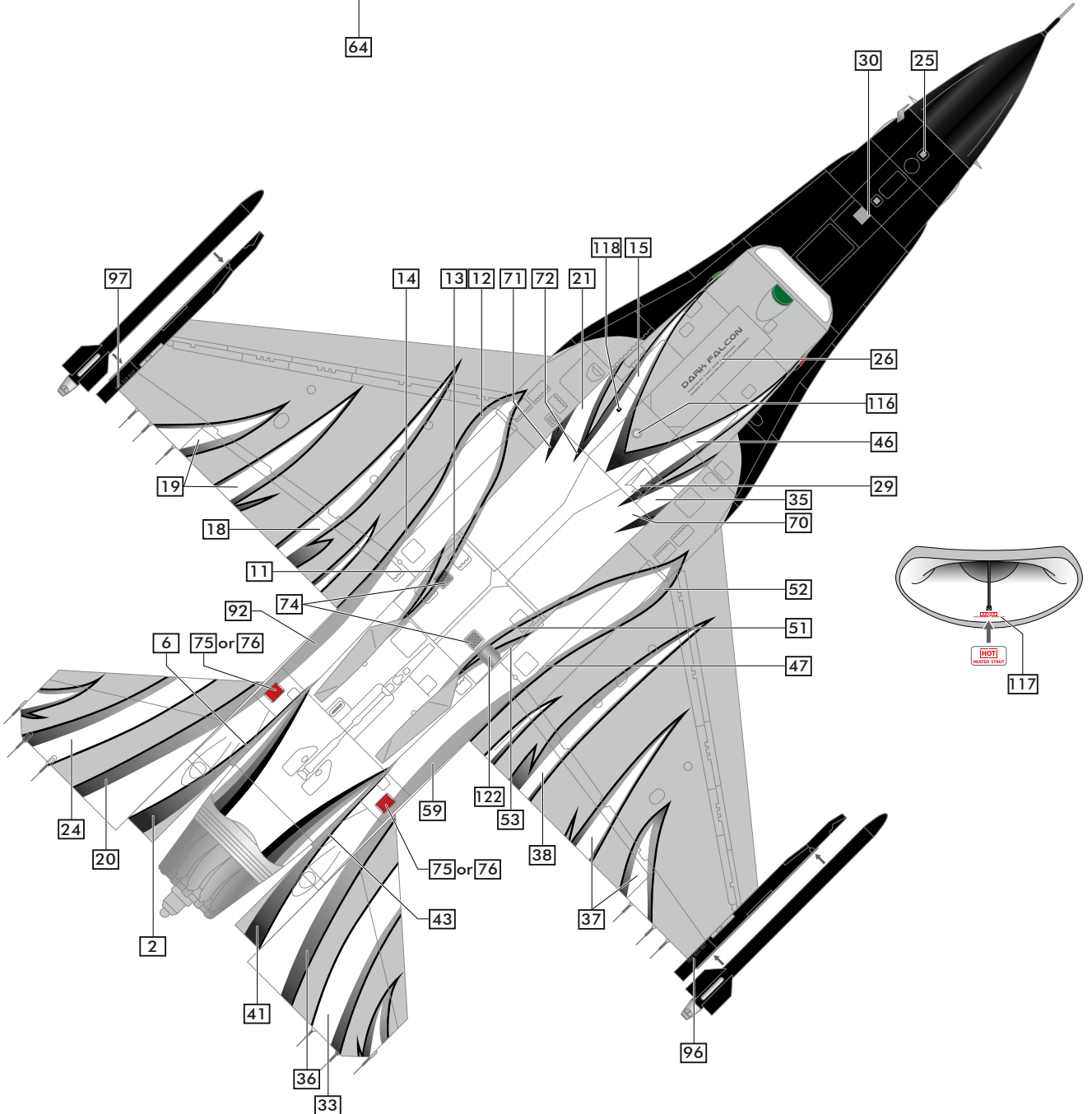
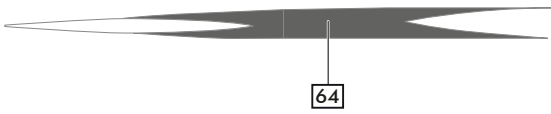
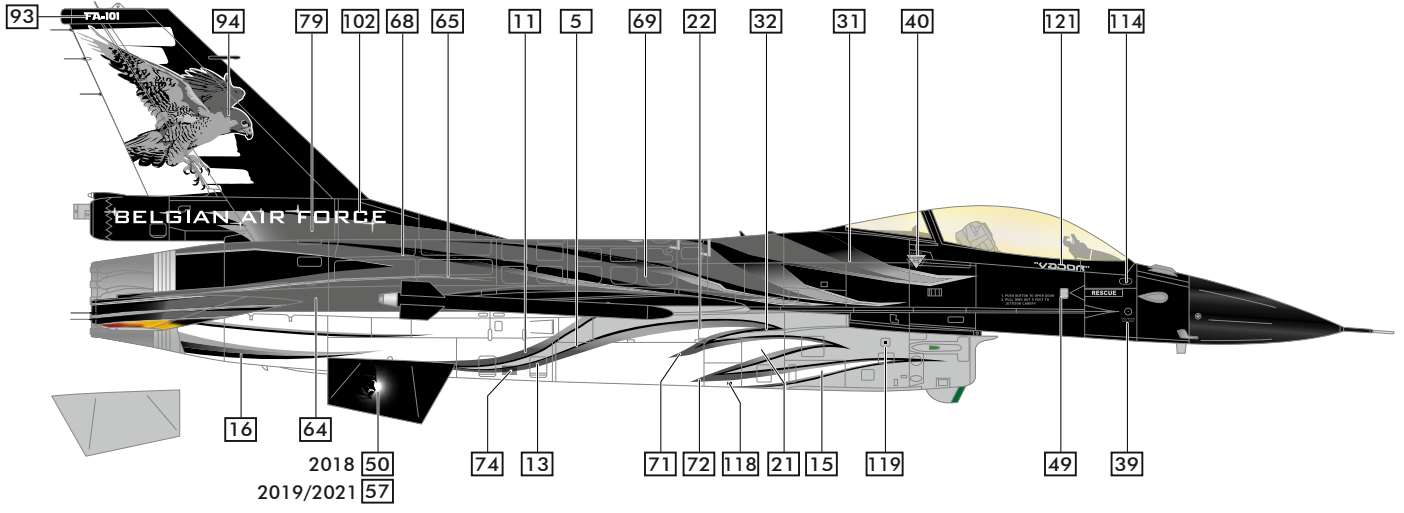

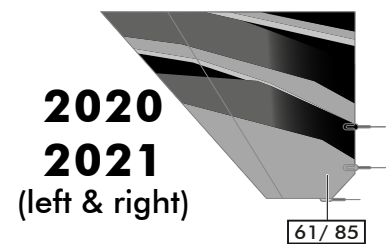
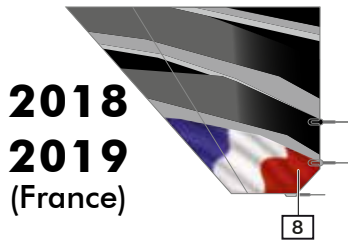
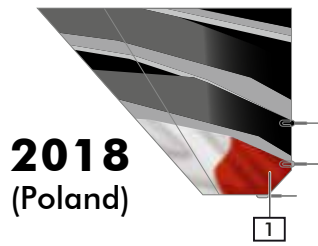
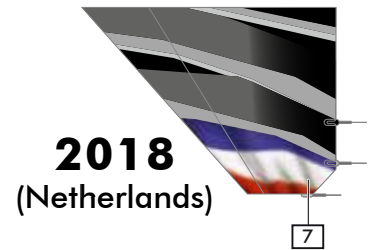
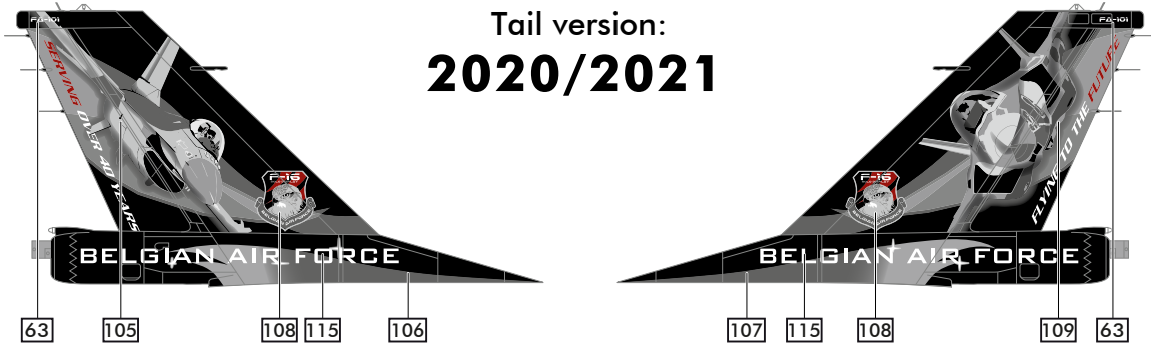
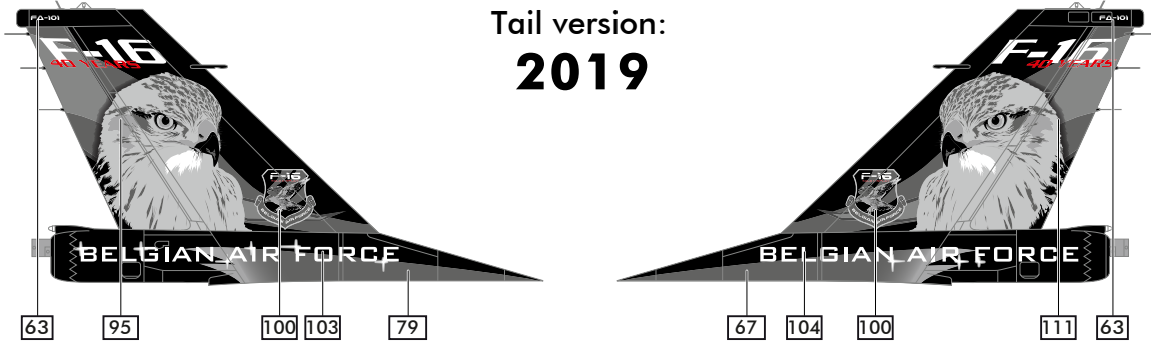

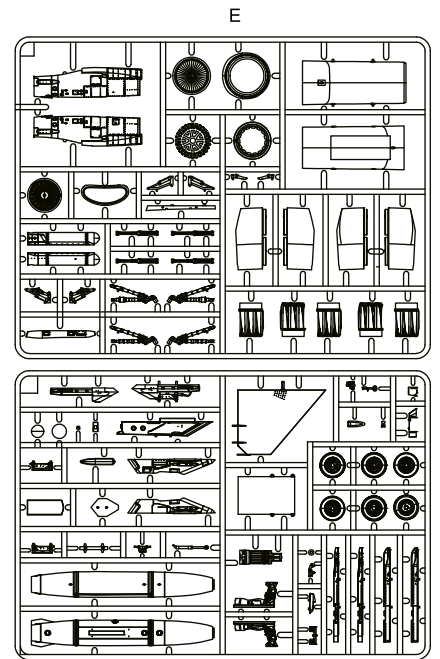
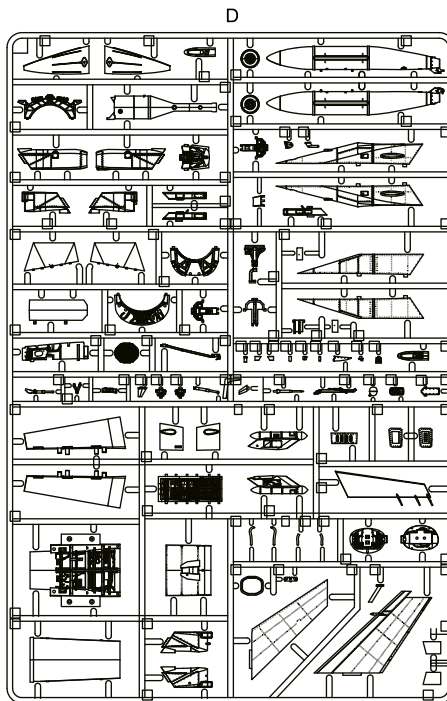
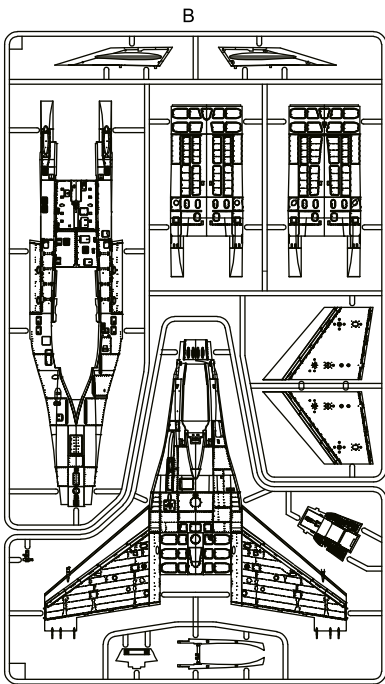
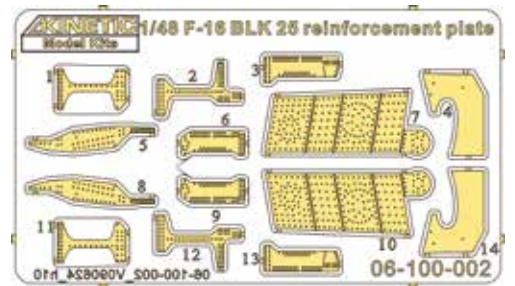
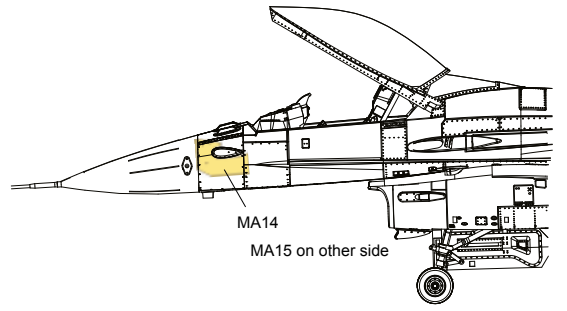
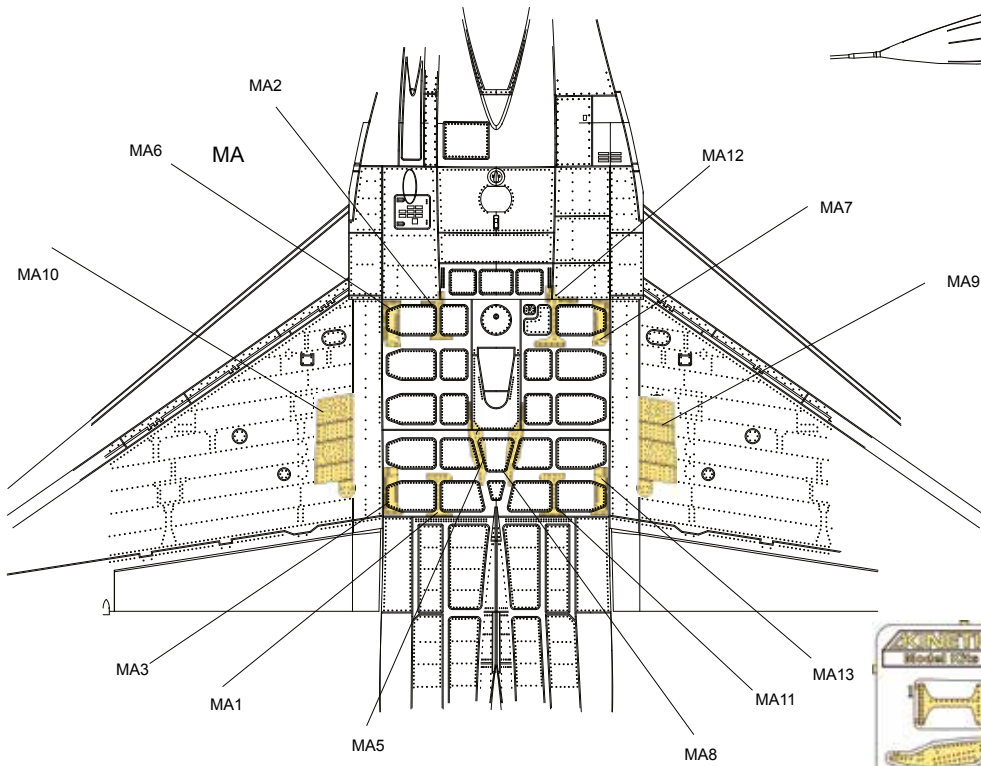

Fx2

C

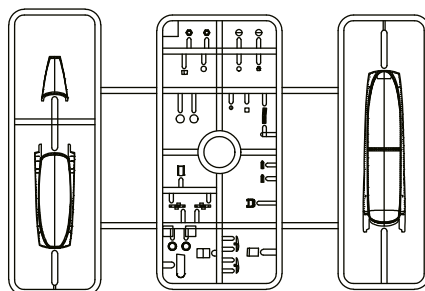

G

# VISITEZ-NOUS EN LIGNE !

VISIT US DIGITALLY!  
BESUCHEN SIE UNS DIGITAL!

 [www.heller.fr](http://www.heller.fr)

 [instagram.com/heller.fr](https://www.instagram.com/heller.fr)

 [facebook.com/heller.fr](https://www.facebook.com/heller.fr)



Choisissez l'article désiré et téléchargez la notice de montage.  
Choose your desired article and download the instructions.  
Wählen Sie den gewünschten Artikel und laden Sie die Anleitung herunter.

**Download all  
instructions!**

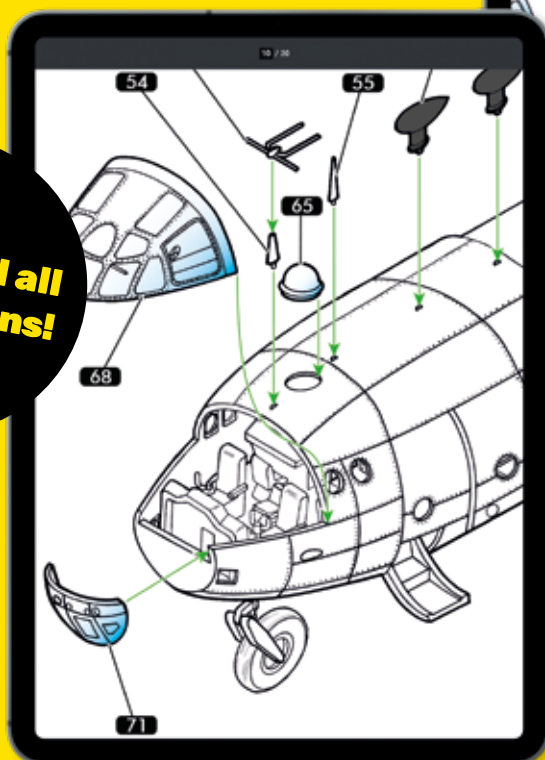

Grossissement des instructions pour  
une vue détaillée.



Enlarge the instructions for a more  
detailed view.

Vergrößern Sie die Anleitung für eine  
detailliertere Ansicht.

**Service consommateurs**  
Pour toute demande de SAV, connectez-vous  
sur notre site [www.heller.fr](http://www.heller.fr).

**Customer Service**  
For after-sales service requests,  
please contact us through our website  
[www.heller.fr](http://www.heller.fr).

**Endverbraucherservice**  
Bitte besuchen Sie uns auf [www.heller.fr](http://www.heller.fr)  
für alle Ersatzteilanfragen.

**Heller Hobby GmbH**  
Erlenbacher Str. 3 • 42477 Radevormwald • GERMANY  
 +49 (0) 2195-92773-0  [info@heller.fr](mailto:info@heller.fr)