

RENAULT 5 TURBO

80150

Français

«Agressive», «monstrueuse», «pour impressionner les filles»: voilà quelques remarques citées au Salon de 1978 quand apparaît la maquette de la R5 Turbo. 2 ans après, les conducteurs émérites apprécient les 204 km/h de cette «bombe» fabriquée en série. Les impressionnantes prises d'air des ailes arrière et son becquet en polyuréthane la rendent immédiatement reconnaissable. Cette audacieuse interprétation de la R5 a incontestablement redoré le blason de la Régie.

English

«Aggressive», «monstrous», «to impress the girls»; these were some of the comments made at the Salon in 1978 when the mock-up of the R5 turbo was unveiled. Two years later, skillful drivers were appreciating the 204 km/h speed of this mass-produced «bomb». The impressive air intakes on the rear wings and its polyurethane trim made it instantly recognizable. This audacious redesign of the R5 without doubt regilded the Régie [state-controlled company] coat-of-arms.

Deutsch

“Aggressiv”, “monströs”, “um die Mädchen zu beeindrucken”; Dies waren einige der Kommentare, die 1978 auf dem Salon abgegeben wurden, als das Modell des R5-Turbo enthüllt wurde. 2 Jahre später schätzten geschickte Fahrer die Geschwindigkeit dieses Fahrzeugs von 204 km/h. Die beeindruckenden Lufteinlässe an den hinteren Kotflügeln und seine Spoiler aus Polyurethan machten ihn leicht erkennbar. Diese Neugestaltung des R5 hat zweifellos das Wappen von Régie Renault neu gestaltet.

Español

«Agresivo», «monstruoso», «para impresionar a las chicas»; estas son algunas de las observaciones citadas en el salón de 1978 cuando apareció la maqueta del R5 Turbo. 2 años después, los conductores consumados apreciaron los 204 km/h de «esta bomba» fabricada en serie. La impresionante toma de aire de las aletas traseras y su alerón de poliuretano le hicieron inmediatamente reconocible. Esta audaz interpretación del R5 ha enaltecido irrefutablemente el «blasón de la Régie».

Italiano

«Aggressiva» e «mostruosa» per impressionare le ammiratrici... sono queste alcune osservazioni fatte in occasione del Salone dell'Automobile del 1978 quando venne presentato il modello R5 Turbo. Due anni dopo, i fortunati proprietari hanno potuto apprezzare i 204 Km l'ora di questa «bomba» costruita in serie. Le impressionanti prese d'aria delle ali posteriori e la sua fusoliera in poliuretano le apportano subito notorietà. Quest'audace interpretazione della R5 ha incontestabilmente ridato ossigeno al blasone della Casa Costruttrice.

Nederlands

«Agressiv», «uhyrlig», «imponerer jentene» er noen av de bemerkninger man kunne høre på utstillingen i 1978 da R5 Turbo-modellen ble vist. To år etter kunne erfarne bilførere nyte de 204 km/t som denne serieproduserte «bomben» kunne prestere. Bakskjermens imponerende luftinntak og nebbet i polyuretan gjør den lett gjenkjennelig. Denne dristige utgaven av R5 har utvilsomt vært et pluss for Renault.



11
 Argent
 Silver
 Silber



14
 Bleu brillant
 Gloss blue
 Glänzend -Blau

85
 Noir de charbon satiné
 Satin coal black
 Seidenmatt-Kohlenschwarz

89
 Bleu moyen mat
 Matt middle blue
 Matt-Mittelblau



27
 Gris mer mat
 Matt sea grey
 Matt-Seegrau

321
 Rouge transparent
 Clear red
 Durchsichtiges Rot

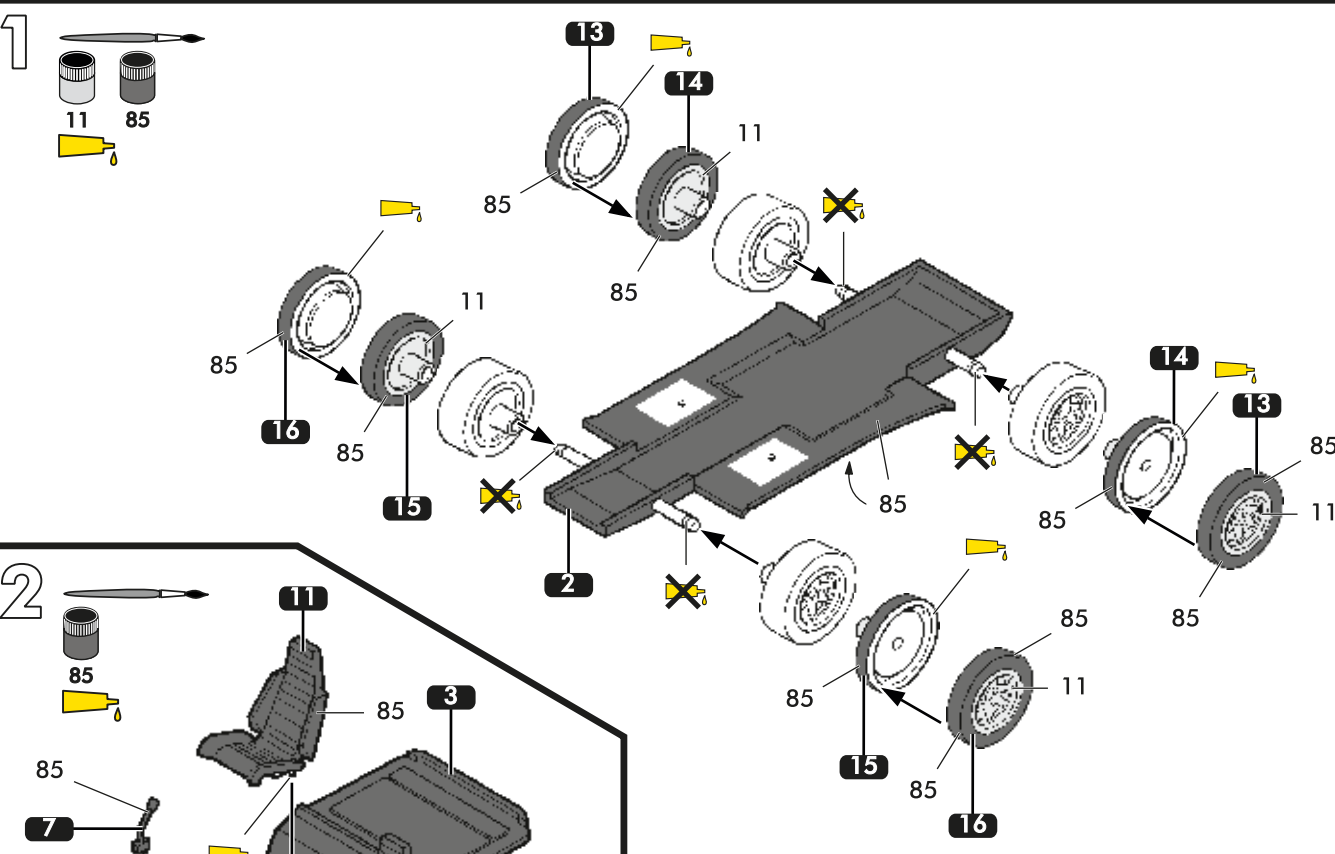

322
 Orange transparent
 Clear orange
 Durchsichtiges Orange

80150-176

1

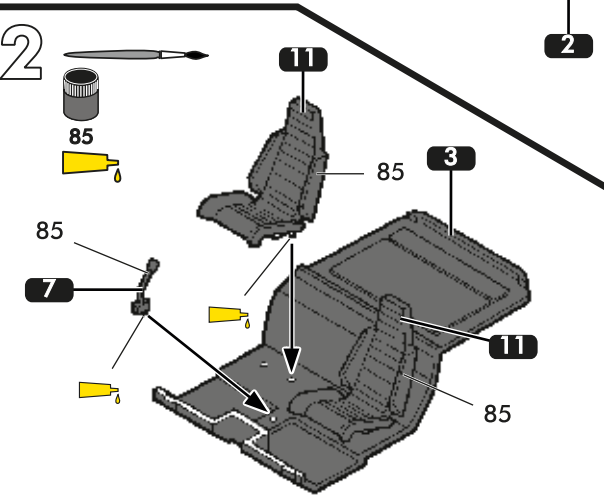

2



3

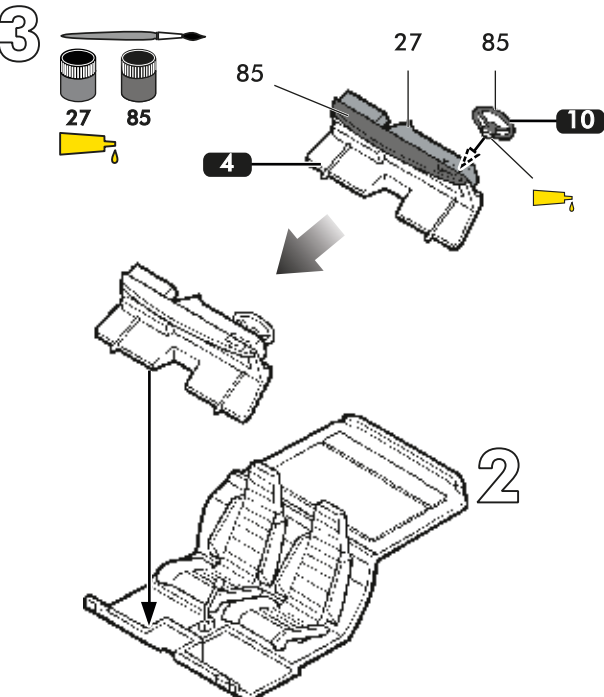

4

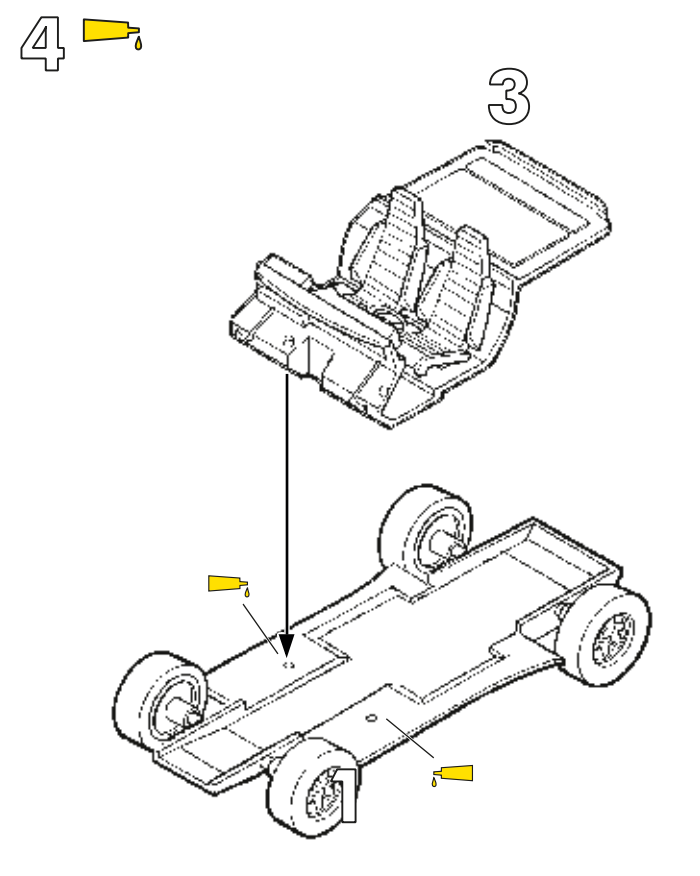

5

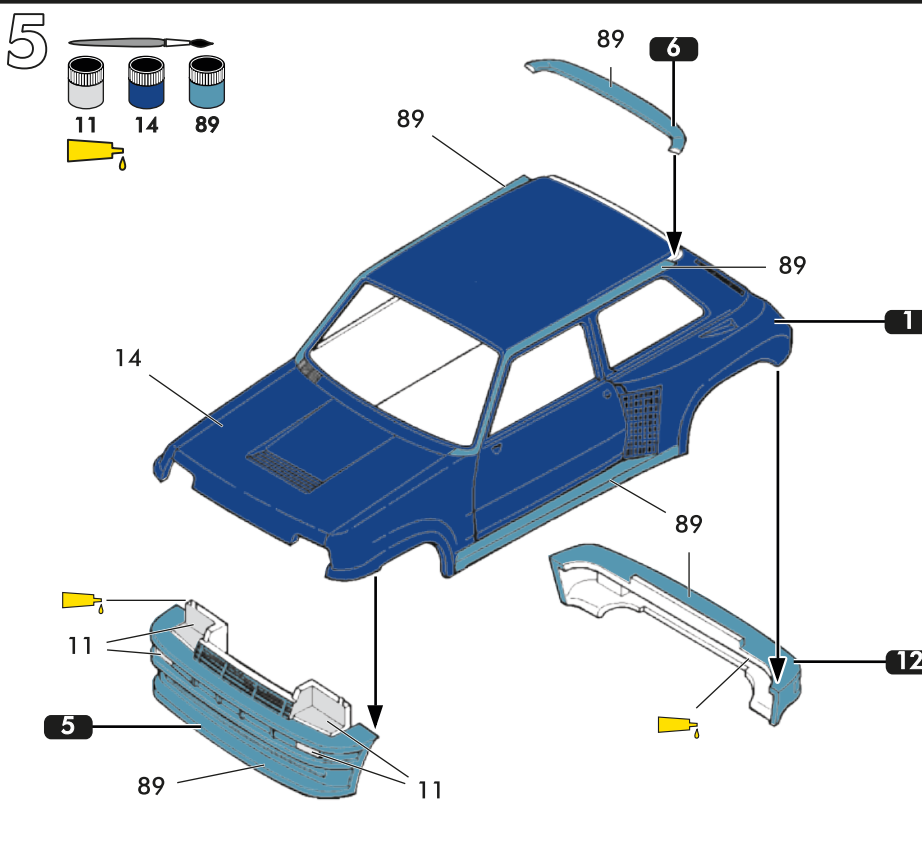

6

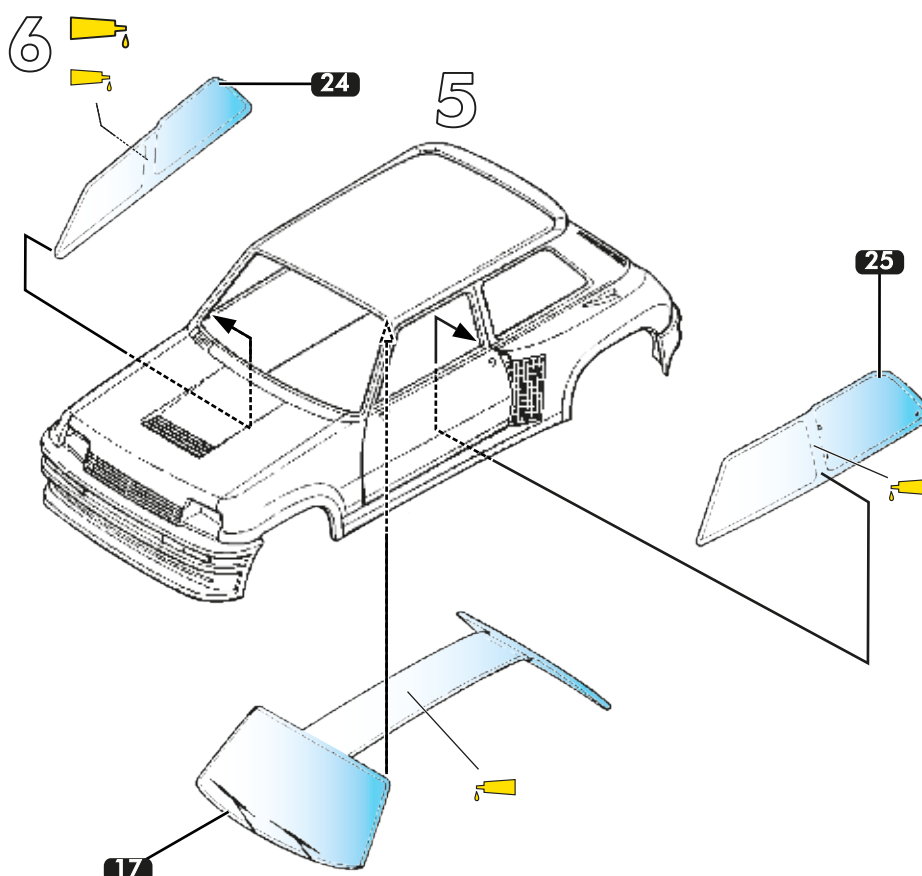

7

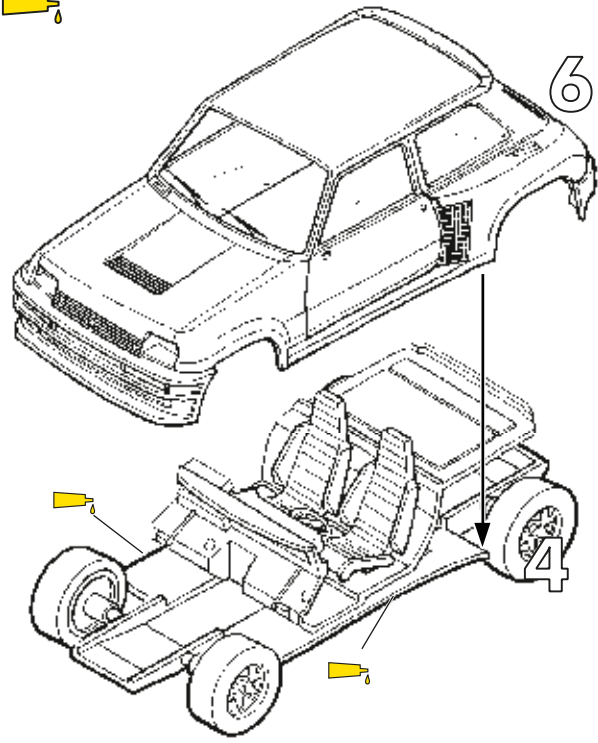

10

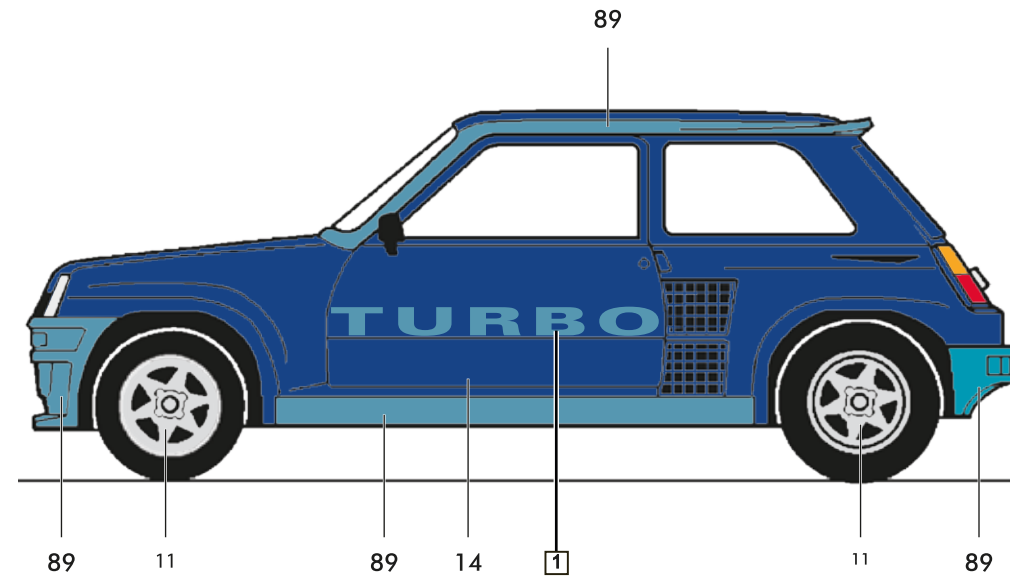
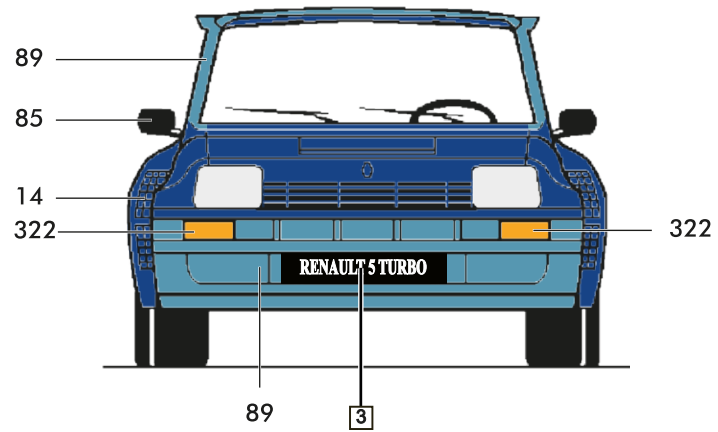
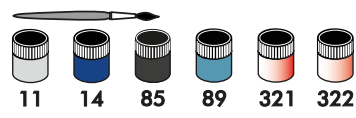

8

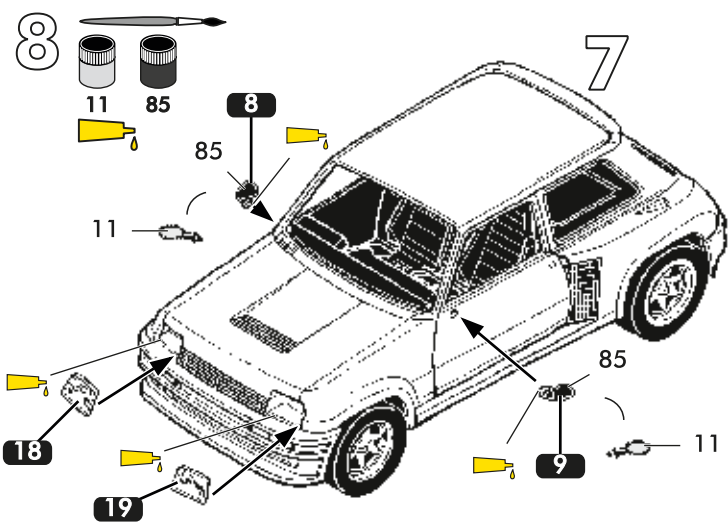

9

